

EN

OPERATING MANUAL
ULTRASONIC DETECTOR



Table of contents

Notes regarding the operating manual..... 1

Safety 1

Information about the device..... 2

Transport and storage..... 3

Operation 4

Maintenance and repair 8

Disposal 8

Notes regarding the operating manual

Symbols



Warning of electrical voltage

This symbol indicates dangers to the life and health of persons due to electrical voltage.



Warning

This signal word indicates a hazard with an average risk level which, if not avoided, can result in serious injury or death.



Caution

This signal word indicates a hazard with a low risk level which, if not avoided, can result in minor or moderate injury.

Notice

This signal word indicates important information (e.g. material damage), but does not indicate hazards.



Info

Information marked with this symbol helps you to carry out your tasks quickly and safely.



Follow the manual

Information marked with this symbol indicates that the operating manual must be observed.

You can download the current version of the operating manual and the EU declaration of conformity via the following link:



SL3000



<https://hub.trotec.com/?id=40314>

Safety

Read this manual carefully before starting or using the device. Always store the manual in the immediate vicinity of the device or its site of use!

- Do not use the device in potentially explosive rooms.
- Do not use the device in aggressive atmosphere.
- Do not immerse the device in water. Do not allow liquids to penetrate into the device.
- Do not expose the device to directly squirting water.
- The device may only be used in dry surroundings and must not be used in the rain or at a relative humidity exceeding the operating conditions.
- Check accessories and connection parts for possible damage prior to every use of the device. Do not use any defective devices or device parts.
- Protect the device from permanent direct sunlight.
- Do not remove any safety signs, stickers or labels from the device. Keep all safety signs, stickers and labels in legible condition.
- Do not open the device with a tool.
- Only use the device if sufficient safety precautions were taken at the surveyed location (e.g. when performing measurements along public roads, on building sites etc.). Otherwise do not use the device.
- Observe the storage and operating conditions (see chapter Technical data).

Intended use

Only use the device for the detection of irregularities in the ultrasound spectrum within the measuring range specified in the technical data.

To use the device for its intended use, only use accessories and spare parts which have been approved by Trotec.

Improper use

Do not use the device in potentially explosive atmospheres, for measurements in liquids and at live parts. Trotec accepts no liability for damages resulting from improper use. In such a case, any warranty claims will be voided. Any unauthorised modifications, alterations or structural changes to the device are forbidden.

Personnel qualifications

People who use this device must:

- have read and understood the operating manual, especially the Safety chapter.

Residual risks



Warning

Ensure sufficient ear protection when there are sources of loud sound. There is a danger of hearing damage.



Warning

Risk of suffocation!
Do not leave the packaging lying around. Children may use it as a dangerous toy.



Warning

The device is not a toy and does not belong in the hands of children.



Warning

Dangers can occur at the device when it is used by untrained people in an unprofessional or improper way! Observe the personnel qualifications!

Notice

To prevent damages to the device, do not expose it to extreme temperatures, extreme humidity or moisture.

Notice

Do not use abrasive cleaners or solvents to clean the device.

Information about the device

Device description

The device SL3000 is used to locate faulty components in various systems. It is based on ultrasonic signals generated e.g. due to friction on faulty parts, inside electrical installations or when gases escape under high pressure.

The ultrasonic signals are detected by the device, converted into audible sound, and output with the corresponding intensity through the headphones. At the same time, the ultrasound level is indicated graphically on a display.

Device depiction

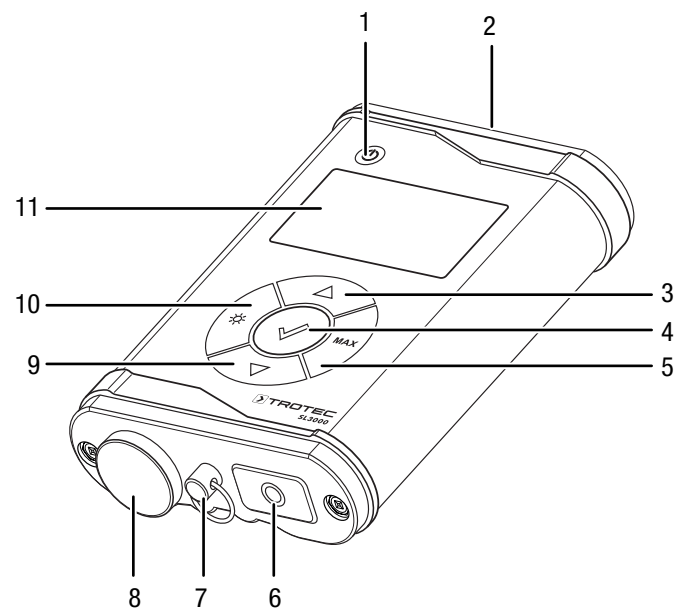

No.	Designation
1	Power button
2	Socket for ultrasound probes
3	Arrow up button
4	OK button
5	MAX button
6	Headphone connection
7	Fixing ring for lanyard
8	Battery compartment with cover
9	Arrow down button
10	Light/brightness button
11	Display

Display

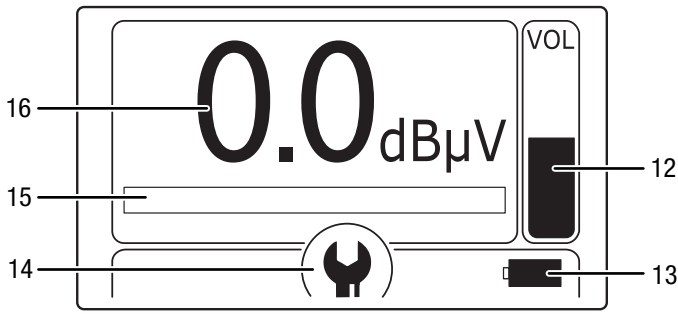

No.	Designation
12	Volume indication
13	Battery status indication
14	Menu indication
15	Sound level scale
16	Indication of measured sound level in dBµV

Technical data

Parameter	Value
Operating frequency	approx. 40 kHz
Display	LC display with background illumination
Connections	Ultrasound probes connector, stereo jack socket
Power supply	2 x 1.5 V AA battery or 2 x min. 1.2 V rechargeable battery
Operating time	approx. 24 hours in battery mode
Operating temperature	-10 °C to +60 °C
Storage temperature	-20 °C to +60 °C
Protection type	Device: IP54 Probe: IP20
Dimensions without probe (length x width x height)	130 x 85 x 30 mm
Weight (incl. battery, without probes)	300 g

Scope of delivery

- 1 x SL3000
- 1 x Headphones
- 1 x Airborne sound probe
- 1 x Acoustic horn (for airborne sound probe)
- 1 x Shotgun with tip (for airborne sound probe)
- 1 x Cable (for headphones)
- 2 x Battery AA 1.5 V
- 1 x Lanyard
- 1 x Transport case
- 1 x Quick guide

Transport and storage

Notice

If you store or transport the device improperly, the device may be damaged.
Note the information regarding transport and storage of the device.

Transport

For transporting the device, use the transport case included in the scope of delivery in order to protect the device from external influences.

Storage

When the device is not being used, observe the following storage conditions:

- Dry and protected from frost and heat
- Protected from dust and direct sunlight
- With a cover to protect it from invasive dust if necessary
- The storage temperature is the same as the range given in the Technical data chapter
- Remove the batteries from the device

Operation

Inserting the batteries

Insert the supplied batteries into the device before first use.

Notice

Make sure that the surface of the device is dry and the device is switched off.

1. Open the battery compartment at the rear of the device by unscrewing the cover.

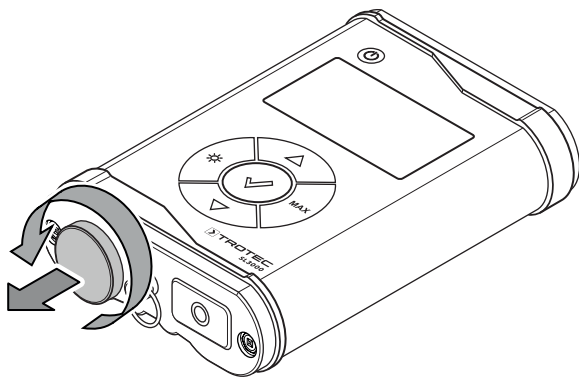

2. Insert the batteries with correct polarity.

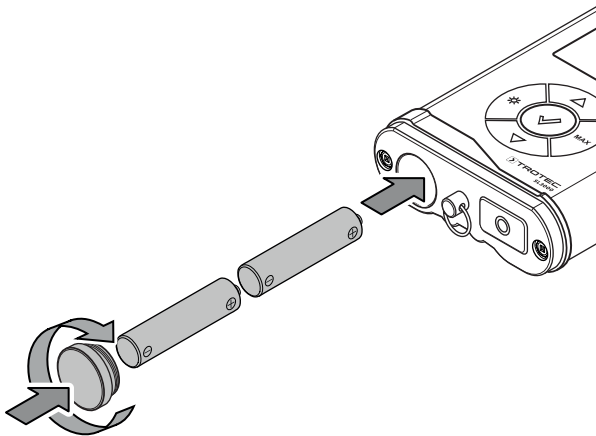

3. Screw the cover back onto the battery compartment.

Inserting / exchanging the probe

The device can be equipped with various probes.

The scope of delivery includes an airborne sound probe.

The airborne sound probe serves the purpose of detecting airborne ultrasonic frequencies even at a distance of up to several metres.

In order to assemble or exchange a probe, please proceed as follows:

1. Remove the probe, if any, by pressing the release button at the probe and carefully pulling the probe out.
2. Insert the probe into the connector. The probe socket is provided with a notch allowing for one plug position only. The plug must noticeably click into place.

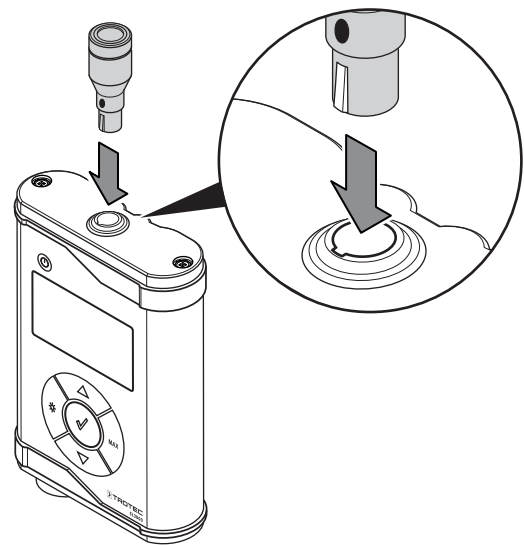

Connecting the headphones

It is recommended to connect the supplied headphones to the device at all times. Human hearing already perceives very subtle signal changes with regard to its volume and intensity, so in addition to the indicative scale on the display you are provided with a valuable acoustic component for a yet more precise detection of ultrasound sources.

Warning

Risk of hearing damage due to unknown, intense ultrasound sources.

The sound spectrum perceptible by human ears lies in the frequency range between 16 Hz and 20,000 Hz. Hence, ultrasound is clearly outside of this range. As a result potential, more or less intense ultrasound sources in the immediate measuring environment go unnoticed without technical aids. Nonetheless, they can inadvertently lead to hearing damage if the auditory system is suddenly faced with the high-intensity ultrasound rendered audible by use of these aids.

For that reason always set the volume control at the headphones to minimum before starting a measurement (narrow end of the wedge at the volume control).

Increase the volume only slowly.

If necessary, reduce the volume when approaching a potential ultrasound source.

Info

Regularly check the headphone cable for damages. Avoid kinking, crushing or pulling.

✓ The device is switched off.

1. Plug the jack plug of the headphone cable into the headphones.

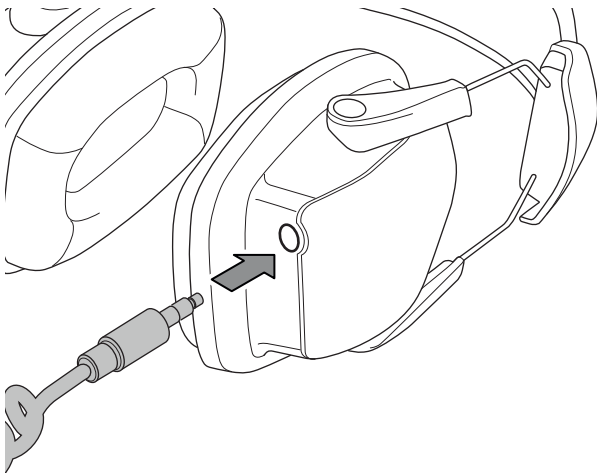

2. Plug the other jack plug into the device's headphone connection.

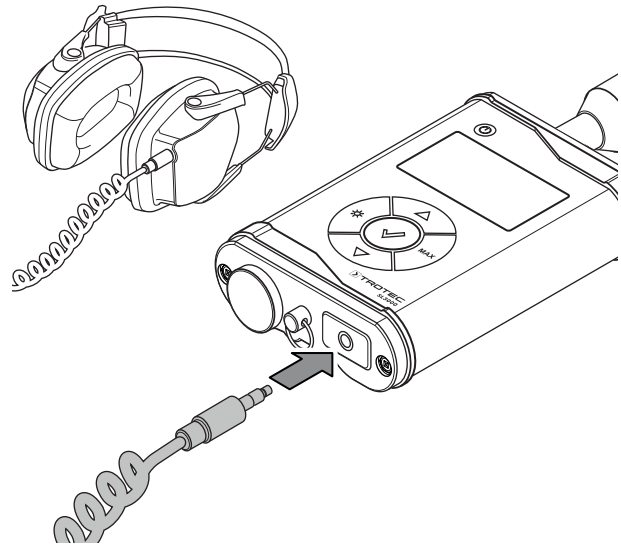

General information regarding the work with the ultrasonic detector

Info

Note that moving from a cold area to a warm area can lead to condensation forming on the device's circuit board. This physical and unavoidable effect can falsify the detection result. In this case, the device emits either no signals or they are incorrect. Wait for a few minutes until the device has become adjusted to the changed conditions before using the device.

Info

Please note that the measurement of an ultrasound source always has to be carried out directly. There must be no objects or persons located between the airborne sound probe and the ultrasound source, for this would hamper the detection process.

Info

In case of very weak ultrasound sources the scale might not indicate a change. If so, use headphones to work with the acoustic component.

Switching the device on

- ✓ A probe is assembled.
 - ✓ The headphones are possibly connected.
1. Press the power button (1).

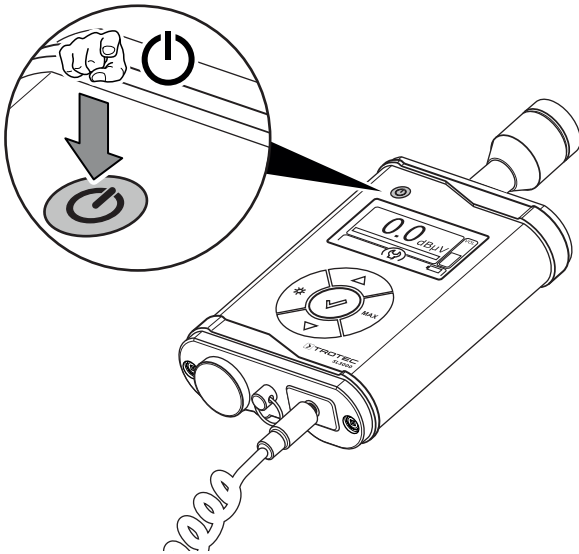

- ⇒ The device is ready for operation.
- ⇒ The current sound level is shown on the display (11).

Adjusting the volume

The volume can be adjusted from -42 dB to 0 dB in increments of 2 dB. The default setting is -22 dB.

1. Press the arrow buttons (3, 9) to increase or reduce the volume.
 - ⇒ The current volume will be indicated on the display.

Using the airborne sound probe

The airborne sound probe is suitable for the following fields of application:

- Leak detection at exposed pressure lines and pipes
- Proving the leakage-related loss at exposed, gas-filled supply networks also during operation
- Leak detection at high-pressure steam installations
- Localization of cracks, poor weld seams or worn flange connections
- Leak detection at all accessible fittings and connecting elements where processes take place in a vacuum or at high pressure
- Detection of signs of wear at ball, roller or needle bearings
- Detection of cavitation e.g. in pumps or compressors
- Localization of electric arcs or corona discharge at electrical components

- ✓ The airborne sound probe is assembled.
- ✓ The device is switched on.
- ✓ The volume of the headphones is set to minimum.

1. Put on the headphones.
2. Test the volume by rubbing the fingertips of thumb and index finger against one another at a distance of approx. 50 cm from the airborne sound probe.
3. Carefully increase the volume at the headphones until you can hear a sound.
4. Now move the airborne sound probe towards the ultrasound source.
5. Since the intensity of the ultrasound source to be detected is initially unknown, down-regulate the volume at the headphones as appropriate when approaching the source of ultrasound.
6. Whilst approaching the source, the sound grows louder and the scale indicates a higher sound level.

Using the attachments for the airborne sound probe

You can also use the probe included in the scope of delivery in combination with the two attachments, which are also included in the scope of delivery.

The attachments serve for an improved pinpoint location of the ultrasonic signal:

- The acoustic horn (19) is suitable for detection even over large distances of several metres.
- The shotgun (18) can be used for a more precise pinpoint location over shorter distances.

The attached tip (17) can, for instance, be used for checking weld seams or valve seals.

To use the attachments, please proceed as follows:

1. Carefully place the rubber grommet of the attachment onto the airborne sound probe. Pay attention not to damage the grid at the airborne sound probe.

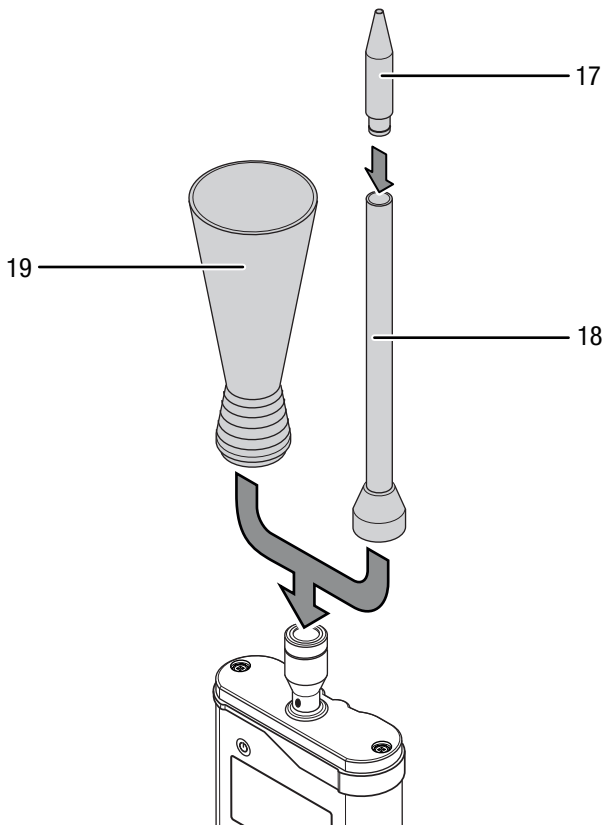

2. If you no longer need the adapter, carefully pull it off the airborne sound probe.

Using structure-borne sound probes (optional)

A structure-borne sound probe utilizes structure-borne sound as bearer of inner states and processes. The device combination thus works like a stethoscope, but specifically for ultrasound.

Structure-borne sound probes are suitable for the following fields of application:

- Early detection of wear at ball, roller or slide bearings
- Checking centrifugal pumps for cavitation
- Tightness tests of fittings
- Continuity testing or functional check of steam traps

- ✓ The structure-borne sound probe is assembled.
- ✓ The device is switched on.
- ✓ The volume of the headphones is set to minimum.

1. Put on the headphones.
2. Hold the probe to the test object.
3. Carefully increase the volume at the headphones until you can hear a sound.
4. Move the probe towards the ultrasound source.
5. Down-regulate the volume at the headphones when approaching the source of ultrasound.
6. Whilst approaching the source, the sound grows louder and the scale indicates a higher sound level.

Activating maximum value detection

1. Press the MAX button (5) to activate the function.
 - ⇒ The maximum value of the current measuring cycle is indicated in the bottom left corner of the display.

Switching on the display illumination

1. Press the light button (10) to switch the display illumination on or off.
 - ⇒ The illumination automatically switches off after approx. 20 s.

Adjusting the display contrast

The display contrast can be adjusted in order to adapt the display to the individual ambient conditions.

The default setting is 50 %.

1. Press the OK button (4) to open the contrast settings menu.
2. Press the arrow buttons (3, 9) to increase or reduce the contrast.
3. Confirm the setting by pressing the OK button (4).

Switching the device off

1. Press the power button (1).
 - ⇒ The display goes out.
 - ⇒ The device is switched off.

Maintenance and repair

Cleaning

Clean the device with a soft, damp and lint-free cloth. Ensure that no moisture enters the housing. Do not use any sprays, solvents, alcohol-based cleaning agents or abrasive cleaners, but only clean water to moisten the cloth.

Repair

Do not modify the device or install any spare parts. For repairs or device testing, contact the manufacturer.

Battery change

A battery change is required when the device can no longer be switched on (see chapter Inserting the battery).

Disposal



The icon with the crossed-out waste bin on waste electrical or electronic equipment stipulates that this equipment must not be disposed of with the household waste at the end of its life. You will find collection points for free return of waste electrical and electronic equipment in your vicinity. The addresses can be obtained from your municipality or local administration. For further return options provided by us please refer to our website www.trotec24.com.

The separate collection of waste electrical and electronic equipment aims to enable the re-use, recycling and other forms of recovery of waste equipment as well as to prevent negative effects for the environment and human health caused by the disposal of hazardous substances potentially contained in the equipment.

You are responsible for deleting any personal data stored on the waste equipment to be disposed of.

In the European Union, batteries and accumulators must not be treated as domestic waste, but must be disposed of professionally in accordance with Directive 2006/66/EC of the European Parliament and of the Council of 6 September 2006 on batteries and accumulators. Please dispose of batteries and accumulators according to the relevant legal requirements.

Trotec GmbH & Co. KG

Grebener Str. 7
D-52525 Heinsberg

☎ +49 2452 962-400

☎ +49 2452 962-200

info@trotec.com

www.trotec.com