

**VS Serials**

VS-035FE, VS-043FE, VS-043HS, VS-043AW-W, VS-057FE, VS-070HS, VS-070HE, VS-070HE-1, TK-070HE-1, VS-070MW-W, VS-070MG-G, VS-102HC, VS-102HCS, VS-102CW-W, VS-102CG-G, VS-121FS, VS-121FE, VS-150AS, VS-150AS-G, VS-150AS-V

## 1 Installation Condition

**Places for application** Invt Series HMI is designed according to the environment of industrial products. Its design specification to ensure that it can work to stabilize in the -20°C to 65°C in most industrial condition. It may not be used in certain outdoor condition, if you need outdoor specific occasions, be sure to consult your provider!

**NEMA** The front panel of the invt HMI match the NEMA4 protection regulations. When the product is properly installed in the disk cabinet match NEMA4 protective provisions, the enclosure remains committed to comply with the provisions of the NEMA4, that is, when the enclosure surface spray liquid, the liquid does not penetrate inside the enclosure.

**Electrical condition** Invt HMI has been tested to meet the European CE standard. Circuit design can be resistant to electrical noise interference, but that does not guarantee that can remove all the electrical noise interference. The correct way of wiring and grounding to ensure correct use.

**Mechanical condition** To ensure that your correct use of the invt HMI products, avoid installation in the condition of strong mechanical vibration.

## 2 Installation Instructions

### 2.1 Installation Guide

#### 2.1.1 Install location

While install equipments behind the HMI, make sure the AC power wiring, PLC output modules, contactors, starters, relays, and other types of electrical interface equipment farther to the back of the enclosure of the HMI.

Keep away of inverter and switching power supply, the input and output of such equipment must be shielded and connected to the system star point.

- 1 -

#### Warning !

In order to comply with ICS Safety Recommendations, you must install an emergency stop switch while use Invt HMI in your control system.

#### Warning ! Power

Do not share the power between HMI and inductive load (such as solenoid switch or solenoid valve).

#### Warning ! Wiring

Some controller 24V DC output power supply cannot provide the current needed of HMI. DC power supply line should be as short as possible (up to no more than 500m for shielded cable, 300m for UTP). tools, Please take the appropriate lightning protection measures when lightning occurs frequently. Be sure AC power cables and high-energy and rapidly switching DC wiring separate from signal cable. Put a resistance and a capacitance in parallel between the ground and the DC insulated power without earthing. This will make a path for static electricity and high-frequency interference. (Suggestions: Resistance, 1M Ω; Capacitance, 4700pF)

#### Connection

Unscrew the screws of line terminal anticlockwise on rear panel. Insert the power cable. Then fasten the screws clockwise. Please insert the power cable laterad when unscrew the plugin line terminal anticlockwise. Then fasten the screws clockwise. Put the terminals into the slot on the rear panel. Caution: Connect the positive pole to the terminal marked "24VDC+", and connect the DC GND to the terminal marked "24VDC-".

#### 2.2.2 Grounding Requirements

**Product shell must be grounded**, DC in the inside of the product is not connected to the actual earth. In order to avoid due to the virtual point grounding can introduce noise into the system, it is best not to land and housing of the DC to earth, but if you have to power to received star point, you must ensure that the ground wire as short as possible cross-sectional area as far as possible,

#### 2.2.3 CE Requirement

To ensure HMI meet EMC specifications, reducing the electrical noise interference, the product of the power terminals on the chassis ground terminal must be connected to a separate # 14 AWG grounding cable. This ground connection must follow the installation instructions directly connected to the system star ground point.

#### 2.2.4 Safty Guide

This section presents recommended installation practices and procedures. Although there is no any two applications are the same, but please carefully consider the following recommendation when installing.

- 3 -

### 2.1.2 Install meet NEMA4 standards



**Specifications** Invt HMI can be installed in the disk cabinet depth of more than 50 to 75 mm (depending on the thickness of the product), it is recommended you install HMI in the front panel of enclosure, do this in order not to affect you open the enclosure front panel and assurance you can smoothly connect the power and communications cables.

**NEMA4 Installation** Put product into the Mounting holes from the back of the panel, install screw into the product of 4 fixed holes shell around the product, and then one by one lock mounting screws until the product is securely fixed to the panel on the panel. (1.2.1 inch, 7 fixed Holes).

**Warning !** Do not fasten the mounting screw with too much strength or the screen will be damaged. (Maximum Torque: 0.2N·m)

**Warning !** In order to ensure the packing specification, all mounting screws provided with products must be used. The curvature of the front-panel cannot be over 0.010 ". With fixed bolt fixed HMI, please use the insulating sleeve to prevent leakage of the machine, it may cause damage to the HMI.

### 2.1.3 Environmental Considerations

-  ● Because of the LCD display inside, the HMI must be used indoors. Make sure the product is installed correctly, and the environment meet.
-  ● Do not use in explosion hazard situations, such as the presence of flammable gas, vapor or dust.
-  ● Do not use in the temperature or high humidity environment, which may cause the device internal product condensate, resulting in damage to the equipment.

## 2.2 Power Connection

Make sure to comply with all local and national electrical standards before installing the product, please consult local suppliers for detail.

### 2.2.1 Power requirement

**Power** Invt HMI products can only used the DC power supply, the provision of the DC voltage range is 24±15% volts of power. This ensures compatibility with most controller DC power supply system. Products within the power regulator circuit is completed by the switching power supply. If the product power regulator circuit is completed by the switching power supply. If the product within two seconds after power display is not shown, please disconnect the power immediately. Check the wiring is correct before re-energized. DC power supply must be properly isolate with the main AC power.

- 2 -

**Warning ! Hardware Install Proposal** The system designer must understand that equipment controller system may malfunction and produce insecurity, electrical conflict and HMI may lead to the run of the device, which may lead to a certain damage to the body of the operator.

If you or your company use programmable control system that require HMI, you must understand the potential security risks and take appropriate preventive measures. Despite your detailed design procedure is developed based on your specific application, but also need to pay attention to the following information about programmable control equipment installed universal precautions, these precautions in line with the NEMA ICS 3-304 Control standards recommended by the controller installation specification.

**Program** In order to meet the security recommendations of the ICS, check and make sure the emergency stop writable register have security restrictions and safety equipment will exceed the limit conditions of the control of the dangerous parts of the plant or equipment in the program to ensure personal absolutely safe.

#### ICS 3-304.81 safety recommendations:

In the mechanical parts that the operator can touch, such as the location of loading machine mechanical automatic operation, you must carefully consider the override or other redundant means, it must be independent out of the programmable controller. You can start or stop the automatic operation of the system. If you need to modify the program on system running a lock or other measures must be considered to ensure that only authorized people can make the necessary security measures to security threats.

\* These recommendations are intended to prevent the risk of equipment failures and the safety measures when modify the program online.

- ICS3-30481 safety recommendations are copied from the NEMA, under license from NEMA ICS3-304 standards

## 2.3 Communication

The communications port in the back of the product can be used to connect such as PLC or other external devices (such as the controller of the connector) and so on.

### 2.3.1 Connection with external devices

**Port** The COM ports on the back of product are used to connect with external devices, Standard 9-pin D-type male ports.

**Cable requirements** On the one side of the cable, it is DB9F that connected to the panel. One the other side, it is adaptive for the connection between the panel and the external control device.

**Attention** For RS485/422 devices, in order to avoid the problem of communication, attention to the communication cable length is not more than 150m. For RS232 devices, attention to the length of communication cable is not more than 15m.

- 4 -

### Attention

If the communication problem occurs, generally you can see fault tips "No Device Response" on the screen, until the communication is established normally. Indicator on the front panel(COM) will be lit and flashing while communication.

Attention that do not put communication cables and AC power cable together and communication cables are not near the location of the sources of electrical noise.

Make sure the communication cables are fixed with both ends of the communication port connectors.

### Pin Assignment

PLC[RS232] Communication port 9-pin D-type female pins arranged in the diagram. This port is used to connect HMI and Controllers with RS232/RS422/RS485 port.  
**Note:** This port is not used for the Invt HMI programming.

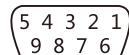

Pin#	PLC[RS232]Fn	PLC[RS422]Fn	PLC[RS485]Fn	* CAN-BUS
1				CANL
2	RX			
3	TX			
4				CANH
5	GND			GND
6		RX-		
7		RX+		
8		TX-	B-	
9		TX+	A+	

### 2.3.2 Connection to PC

**Port** The USB port on the back of HMI used to connection for PC to HMI. B-type USB interface.

**Connect** This port can be connected by communication cables ( P/N : Invt\_HMI\_PC ) connect to PC.

**Port Activation** This port will be automatically activated while the program is running for downloading from PC

### Invt\_HMI\_PC cable diagram



- 5 -

### 2.3.3 Connection with 3G/4G/WIFI Antenna

**WITH 3G/4G/WIFI** VS-043AW-W , VS-070MW-W , VS-070MG-G , VS-102CW-W , VS-102CG-G VS-150AS-V , VS-150AS-G

**Port** The 3G/WIFI port is used to connected to external antenna.

**Connect** These two ports are connected by appropriate connection cable ( P/N:HMI\_WL ) and antenna ( P/N:HMI\_WF、 HMI\_3G).

**Port Fn** In order to avoid the communication problem, HMI\_WF is only used as WIFI Antenna and HMI\_3G is only used as 3G Antenna.

### HMI Antenna Base、3G/4G/WIFI Antenna Sketch

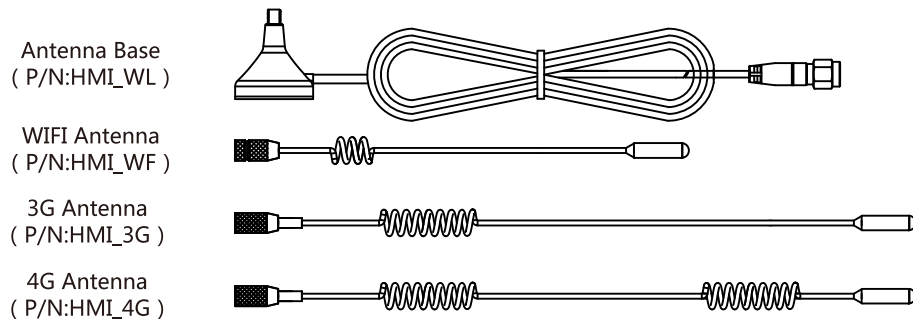

### 2.4 CE Requirement

Invt HMI conforms with the EMC regulations.

- EMC (electromagnetic compatibility) regulations electromagnetic interference radiation and resistance.
- HMI has CE marking and conforms with the EMC regulations.

HMI is designed to ensure it can be worked in the standard limit electromagnetic noise environment (resistance), and does not produce high-intensity electromagnetic noise radiation to the surrounding environment (radiation). Installed correctly in accordance with the instructions in this manual, the product in full compliance with electrical safety standards of the European Community.

**Compatibility standard** HMIs are designed to meet the industrial environment and electromagnetic compatibility.

- EN 55032, Class A in radiation levels
- EN 55032 radiation standard for industrial environment (equivalent to U.S. FCC Class A standards)
- EN 55024 standard for generic resistance of industrial environment

- 6 -

### 3.1 Common Diagram

Unit: mm

4.3"/5.7"/7"/10.2"

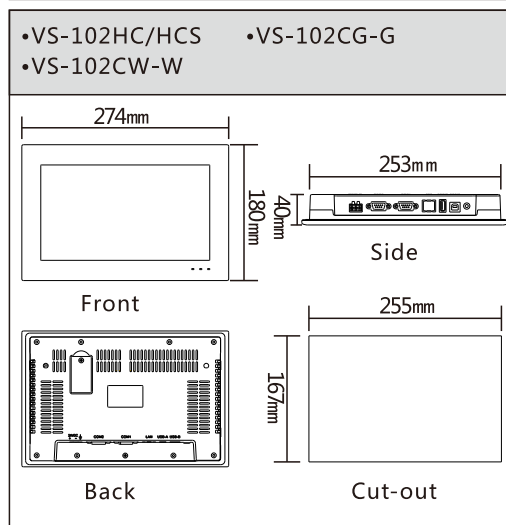
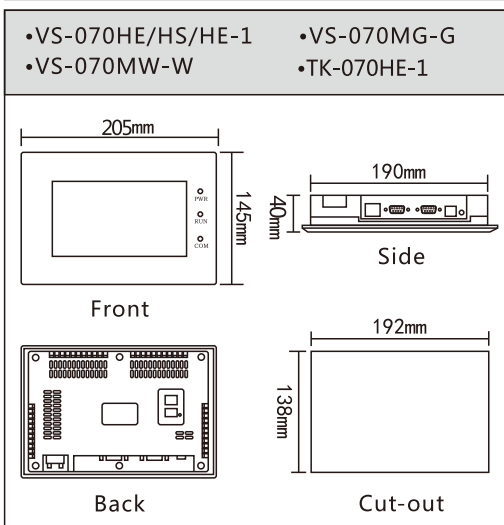
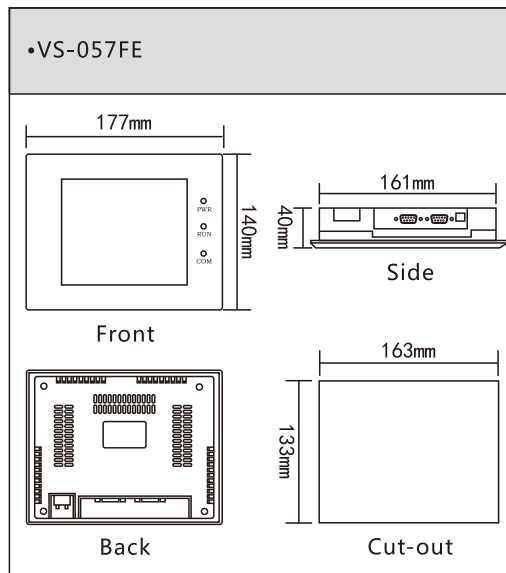
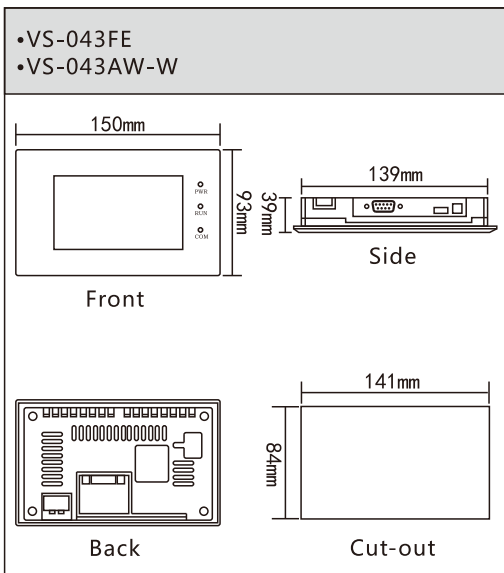

### 3.1 Common Diagram

Unit: mm

12.1"/15"

