

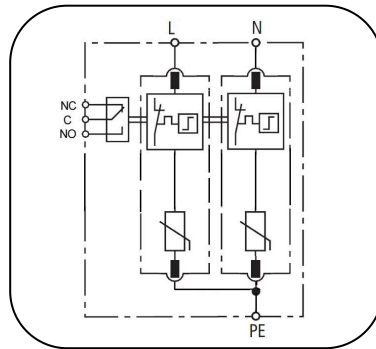

CE

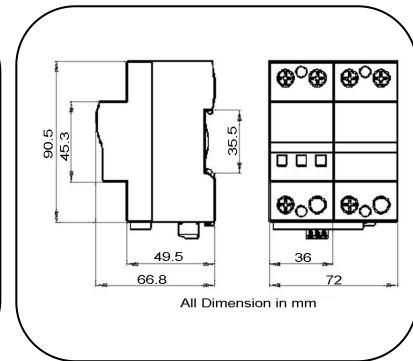

Basic circuit diagram



Dimension drawing

Type 1+2 surge arrester designed for low-voltage power supply system protection against surges at the boundaries from lightning protection zone 0_B -2 and higher.

- Class I+II/ B+C SPD in accordance with IEC61643-11 and UL1449-4th, for use in TN-S systems
- Non-pluggable protection module to avoid flashover caused by high impulse current
- High surge capacity of 12.5kA 10/350 per pole
- Reliable supervision due to disconnection device
- Fault indication by red indication flag in window
- Fast response
- With remote alarm terminal optional

Part No.	B12.5V/175(-S)/2P	
In accordance with	IEC61643-11:2011; UL1449-4th	
Category IEC/VDE	I+ II / B+C	
Max. continuous operating voltage V _{Uc} (AC/DC)	175 /225	
Nominal discharge current(8/20) I _n	12.5kA	
Max. discharge current(8/20) I _{max}	65kA	
Lightning impulse current(10/350) I _{imp}	12.5kA	
Voltage protection level	@I _n	<0.7kV
	@VPR	<0.6kV
Response time	≤25 ns	
Follow current	No	
Backup fuse(only required if not already provided in mains)	250A gL/gG	
Operating temperature range	- 40°C ~ + 80°C	
Cross-section of connection wire	Single-strand 35mm ² ; multi-strand 25mm ²	
Mounting	35mm DIN-rail in accordance with EN 50022/DIN46277-3	
Enclosure material	thermoplastic; extinguishing degree UL94 V-0	
Degree of protection	IP20	
Installation width	4 modules, DIN 43880	
Thermal disconnecter	Internal red - failure	
Remote alarm contact	Optional	
Approvals, Certifications	CE	
Additional data for Remote Alarm Contacts		
Remote alarm contact type	Isolated Form C	
Switching capability Un/I _n	AC: 250V/0.5A DC: 250V/0.1A; 125V/0.2A; 75V/0.5A	
Max. Size of connecting wire	Max. 1.5mm ² (or # 16AWG)	