



## NRE8 Electronic Overload Relay

### 1. General

- 1.1 Certificates: CE, UKrSEPRO, UL;
- 1.2 Electrical ratings: AC50/60Hz, 690V;
- 1.3 Standards: IEC/EN 60947-4-1, UL508

### 2. Type designation

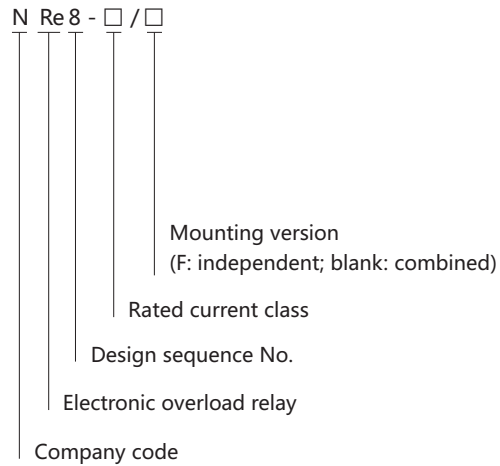

### 3. Features

- 3.1 Three-phase electronic type, tripping class10A;
- 3.2 Energy saving up to 80% compared with bimetallic type;
- 3.3 Phase-failure protection;
- 3.4 Current setting continuously adjustable;
- 3.5 Two indicator lights available for indicating normal, overload time-delay, phase-failure and phase-failure time-delay status respectively;
- 3.6 Manual test mechanism;
- 3.7 Manual reset button;
- 3.8 A pair of N/C and N/O contacts;
- 3.9 Two mounting versions: independent or combined with a contactor.

### 4. Technical data

- 4.1 Main Circuit: Rated insulation; Voltage: AC 690V; Rated frequency: 50/60Hz;
- 4.2 Auxiliary Circuit: Rated insulation; Voltage: AC 400V; Rated frequency: 50/60Hz; See table below for other ratings.

Utilization category	AC-15		DC-13
Rated operational voltage Ue (V)	230	400	220
Rated operational current Ie (A)	2.5	1.5	0.2
Conventional heating current (A)	5		

4.3 Wiring. Connection of main circuit is PVC insulation copper conductor or cable. See table below for details:

Current range (A)	Cross section area (mm <sup>2</sup> )	Length (m)	Number of piece
I≤8	1.0	1	1
8 < I≤12	1.5	1	1
12 < I≤20	2.5	1	1
20 < I≤25	4.0	1	1
25 < I≤32	6.0	1	1
32 < I≤50	10	1	1
50 < I≤65	16	1	1
65 < I≤85	25	1	1
85 < I≤115	35	1	1
115 < I≤150	50	2	1
150 < I≤175	75	2	1
175 < I≤225	95	2	1
225 < I≤250	120	2	1
250 < I≤275	150	2	1
275 < I≤350	185	2	1
350 < I≤400	240	2	1
400 < I≤500	150	2	2
500 < I≤630	185	2	2

#### 4.4 Protection Characteristics

4.4.1 Operation characteristic under three-phase balanced-load status as per the table below.

Series No.	I/I <sub>n</sub>	Operating time	Test condition	Ambient temperature (°C)
1	1.05	< 2h non-tripping	Cold status	(20±5)°C
2	1.20	< 2h tripping	Starts from hot status, right after item no.1	
3	1.50	≤ 2 min		
4	7.20	2s < T <sub>p</sub> ≤ 10s	Cold status	

Under three-phase operation, if relay current reaches and maintains 1.05 times of the current setting, the green lamp flashes and red lamp does not light up, which indicates that the relay is not at over-load time-delay status, which equals to non-operation in 2 hours in serial No. 1 of the table above. A current tolerance for serial No.1 is -3%, and a current tolerance for No.2 is +3%. Cold status implies the status of the power re-energized of main circuit of relay 5 seconds after its power off.

4.4.2 Operation characteristic under phase-failure status as per the table below.

Series No.	I/I <sub>n</sub>		Operating time T <sub>p</sub>	Test condition	Ambient temperature °C
	Any two phases	The third phase			
1	1.0	0.9	< 2h non-tripping	Starts from cold status	(20±5)°C
2	1.15	0	< 2h tripping	Starts from hot status, right after item No.1	

Under phase failure operation, if one phase has the current = 0, the other two phases have the current ≥ 1.15 times of the current setting, then, the red lamp flashes, and green lamp lights up, which indicates that the relay is at time-delay release status.

As to this table, the permissible error of the No.1 circuit is -3%, No.2 circuit +3%

4.5 Tripping Curve

Tripping class 10A

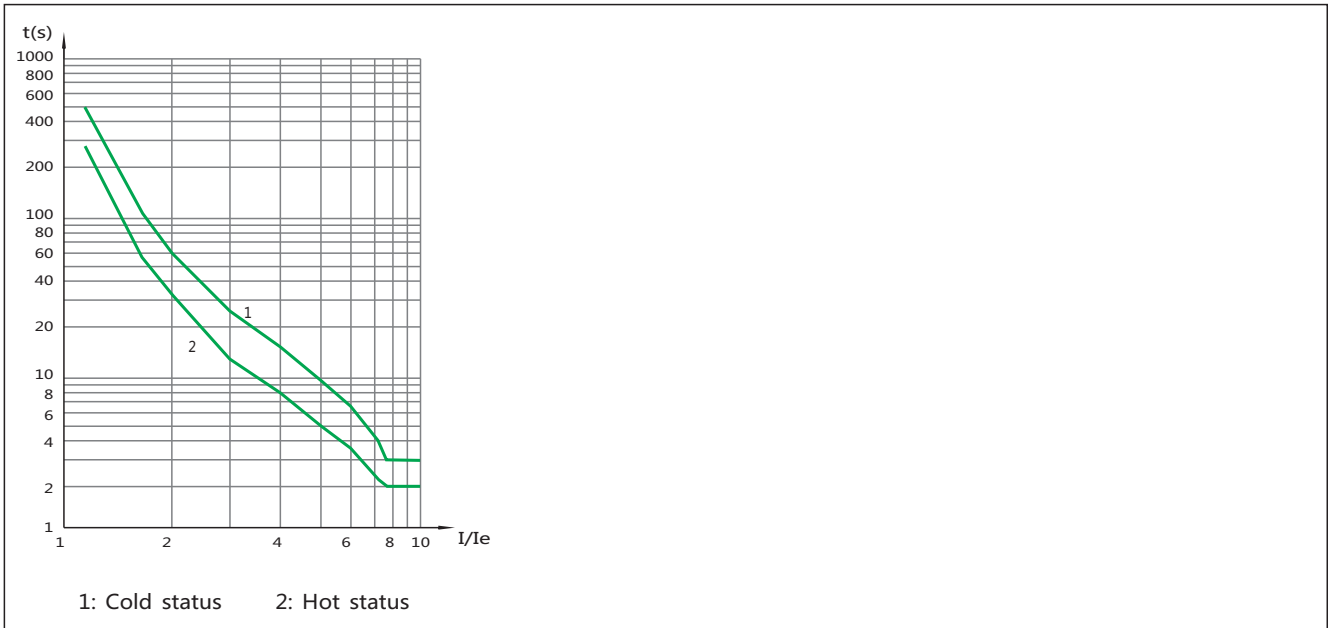

5. Overall and mounting dimensions (mm)

5.1 For Combined Mounting

NRE8-25

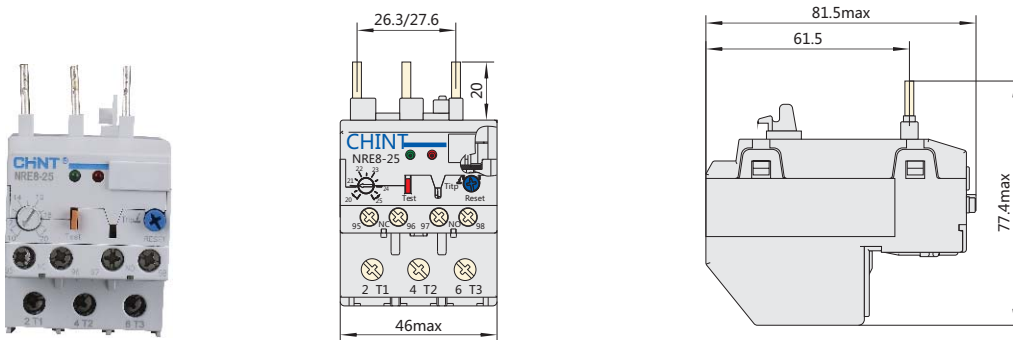

NRE8-25/F

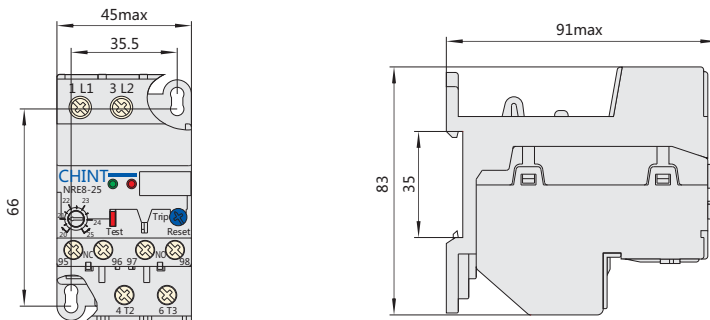

NRE8-40

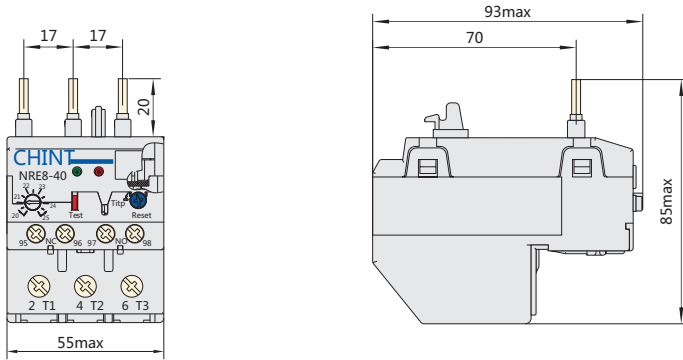

NRE8-40/F

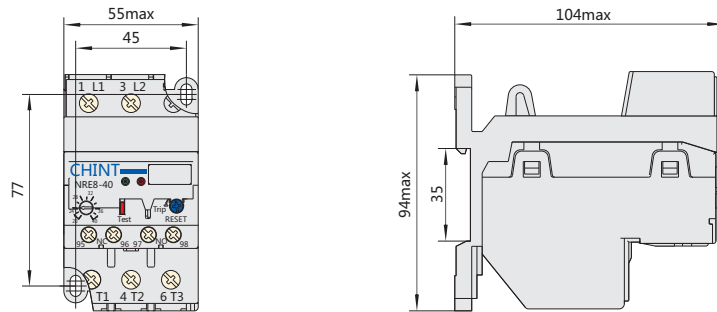

NRE8-100

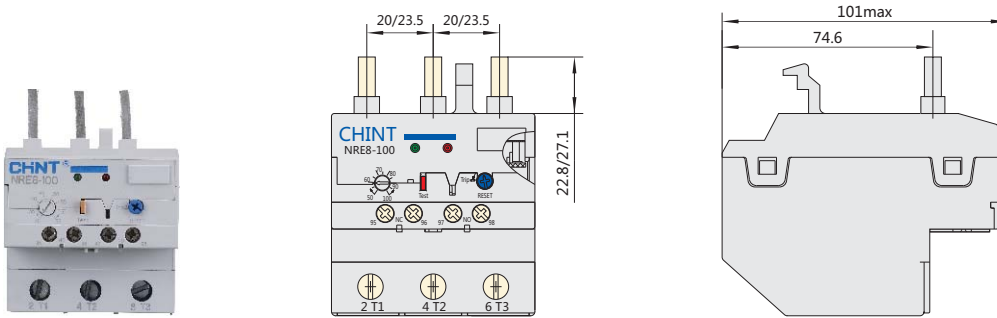

NRE8-100/F

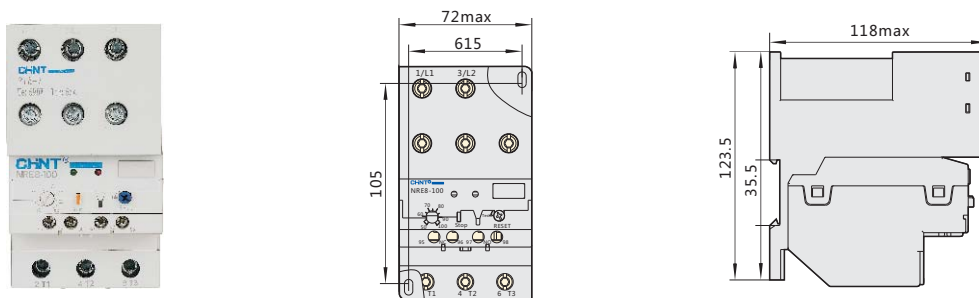

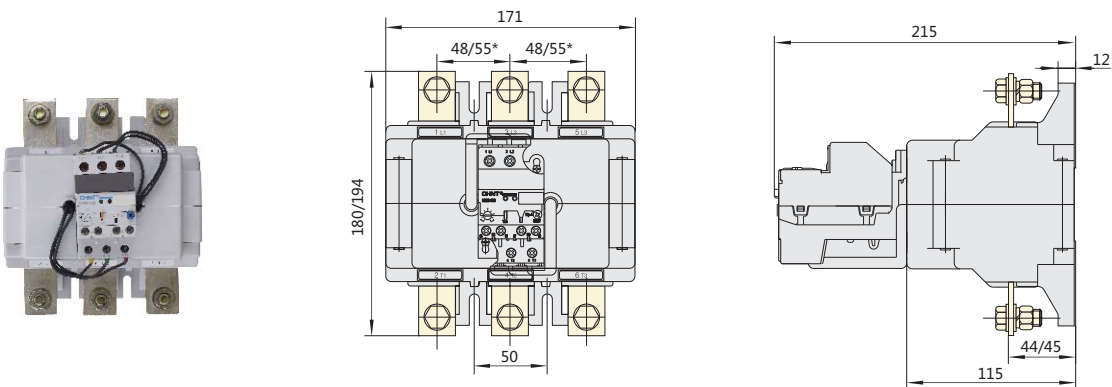
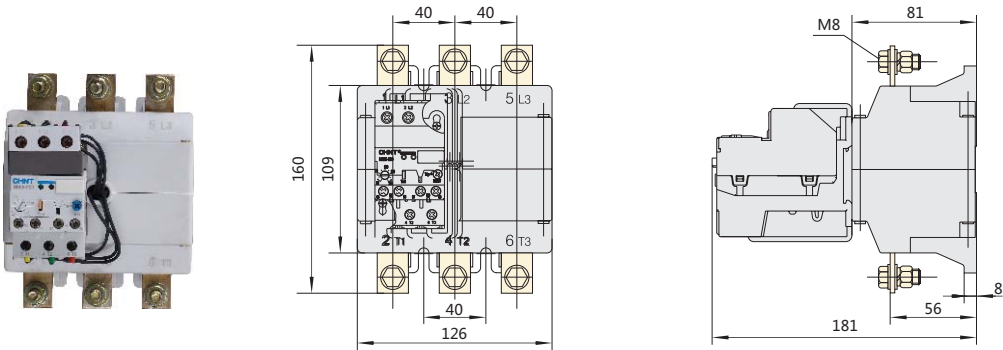

Note: Dimension with '\*' for the product above 400A.

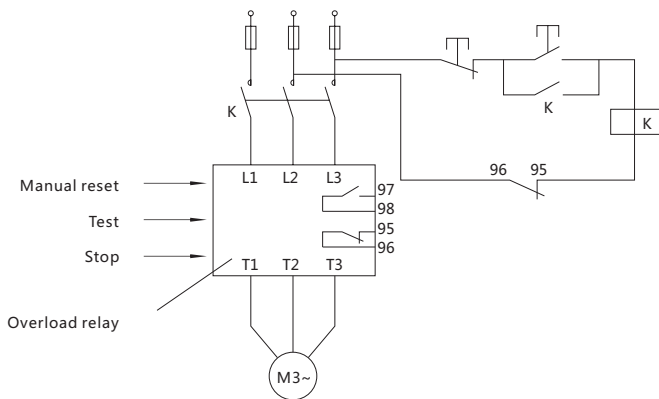

## 6. Applications



## 7. Accessories





### 7.1 Mounting base

Mounting base	Description	Application
	NRE8-25 mounting bracket	Incorporates with NRE8-25 to form an independently mounted product

Mounting base	Description	Application
	NRE8-40 mounting bracket	Incorporates with NRE8-40 to form an independently mounted product
	PIA-7 mounting bracket	Incorporates with NRE8-100 to form an independently mounted product

Note: NRE8-100 without mounting bracket

## 7.2 Assembly with contactors

Thermal overload Relay	Rated current (A)	Current setting range (A)	Model of recommended contactor	Model of recommended fuse
 NRE8-25	1.2	0.6~1.2	NC1-09~18 NC1-25~32 NC7-09~18 NC7-25~38	RT36-4 (NT00-4)
	2.4	1.2~2.4		RT36-6 (NT00-6)
	4	2~4		RT36-10 (NT00-10)
	8	4~8		RT36-16 (NT00-16)
	10	5~10		RT36-20 (NT00-20)
	12	7~12		RT36-25 (NT00-25)
	20	10~20		RT36-40 (NT00-40)
	25	20~25		RT36-50 (NT00-50)
 NRE8-40	4	2~4	NC1-40~65 NC7-40~65	RT36-10 (NT00-10)
	8	4~8		RT36-16 (NT00-16)
	10	5~10		RT36-20 (NT00-20)
	20	10~20		RT36-40 (NT00-40)
	40	20~40		RT36-80 (NT00-80)
 NRE8-100	65	30~65	NC1-40~65, NC7-40~65 NC8-40~65	RT36-160 (NT00-160)
	100	50~100		NC1-80~95, NC7-80~95 NC8-80~100
 NRE8-200	120	85~120	NC2-115, NC2-150 NC2-185, NC2-225	RT36-250 (NT1-250)
	160	110~160		RT36-315 (NT2-315)
	200	140~200		RT36-400 (NT2-400)
 NRE8-630	250	170~250	NC2-225, NC2-265 NC2-330, NC2-400 NC2-500, NC2-630	RT36-500 (NT3-500)
	315	215~315		RT36-630 (NT3-630)
	400	275~400		RT36-800 (NT4-800)
	500	340~500		RT36-1000 (NT4-1000)
	630	430~630		RT36-1000 (NT4-1000)