



AMERICANTM
CONTROL
ELECTRONICS

VFD6x3 Series

USER MANUAL

VFD603-5
VFD643-4
VFD643-5

Dear Valued Consumer:

Congratulations on your purchase of the **VFD6x3 Series** drive. This User Manual was created for you to get the most out of your new device and assist with the initial setup. Please visit www.americancontrolelectronics.com to learn more about our other drives.

Thank you for choosing **American Control Electronics!**

Copyright © 2017 by
American Control Electronics

No part of this document may be reproduced or transmitted in any form without written permission from American Control Electronics®. The information and technical data in this document are subject to change without notice. American Control Electronics® makes no warranty of any kind with respect to this material, including, but not limited to, the implied warranties of its merchantability and fitness for a given purpose. American Control Electronics® assumes no responsibility for any errors that may appear in this document and makes no commitment to update or to keep current the information in this document.

Safety First!

SAFETY WARNINGS



Text in gray boxes denote important safety tips or warnings. Please read these instructions carefully before performing any of the procedures contained in this manual.

- **DO NOT INSTALL, REMOVE, OR REWIRE THIS EQUIPMENT WITH POWER APPLIED.** Have a qualified electrical technician install, adjust and service this equipment. Follow the National Electrical Code and all other applicable electrical and safety codes, including the provisions of the Occupational Safety and Health Act (OSHA), when installing equipment.
- Reduce the chance of an electrical fire, shock, or explosion by using proper grounding techniques, over-current protection, thermal protection, and enclosure. Follow sound maintenance procedures.



It is possible for a drive to run at full speed as a result of a component failure. American Control Electronics strongly recommends the installation of a master switch in the main power input to stop the drive in an emergency.

Circuit potentials are at 115 VAC or 230 VAC above earth ground. Avoid direct contact with the printed circuit board or with circuit elements to prevent the risk of serious injury or fatality. Use a non-metallic screwdriver for adjusting the calibration trim pots. Use approved personal protective equipment and insulated tools if working on this drive with power applied.

Table of Contents

Section 1. Variable Frequency Drives.....	1
Section 2. Specifications	2
Section 3. Dimensions.....	3
Section 4. Installation.....	6
Mounting	6
VFD603-5	6
Speed Adjust Potentiometer.....	7
VFD643-4	8
VFD643-5	9
Wiring	10
Shielding Guidelines.....	11
Line Fusing	12
Connections.....	13
AC Line Input	13
Motor Connections (Single Phase Operation)	14
Motor Connections (Three Phase Operation).....	14
Speed Adjust Potentiometer	16
Enable Switch	16
Direction Switch	16
Analog Input Signal	17
Section 5. Operation.....	18
Before Applying Power	18
Select Switches	19
AC Input Voltage Signal (JMP501 and JMP502)	19
Fault Reset Type Select (JMP503).....	19
Control Signal Selects (JMP504 and JMP505).....	19
Stopping Method Select (JMP506)	20
Startup	22
Starting and Stopping Methods	23
Automatic Restart Upon Power Restoration.....	23
Line Starting and Stopping	23
Decelerating to Zero Speed	24
Quick Reversing	25

Section 6. Calibration	26
4-20 mA Offset (ZERO SET)	27
Minimum Speed (MIN)	28
Maximum Speed (MAX)	28
Acceleration (ACCEL)	29
Deceleration (DECEL)	29
Torque (TORQUE LIMIT)	30
Boost (BOOST)	31
Slip Compensation (SLIP COMP)	31
DC Injection Braking Current (BRAKE CURRENT)	32
DC Injection Braking Time (BRAKE TIME)	33
Section 7. Application Notes	34
Multiple Fixed Speeds	34
Adjustable Speeds Using Potentiometers In Series	35
Independent Adjustable Speeds	36
Independent Adjustable Speeds with Direction Switch	37
RUN/JOG Switch - Enable Connection	38
RUN/JOG Switch - Potentiometer Connection	39
Section 8. Diagnostic LEDs	40
Section 9. Troubleshooting	42
Before Troubleshooting	42
Section 10. Accessories & Replacement Parts	45
Section 11. Optional C510 Capacitor Kit	46
Unconditional Warranty	48

List of Tables

Table 1	Recommended Line Fuse Sizes	12
Table 2	202-0108 Capacitor Values and Carrier Frequency	46

List of Figures

Figure 1	VFD603-5 Dimensions.....	3
Figure 2	VFD643-4 Dimensions.....	4
Figure 3	VFD463-5 Dimensions.....	5
Figure 4	Speed Adjust Potentiometer	7
Figure 5	AC Line Connections.....	13
Figure 6	Single Phase Motor Connections.....	15
Figure 7	Single Phase Motor Connections - Reversing	15
Figure 8	Three Phase Motor Connections	15
Figure 9	Potentiometer and Switch Connections	16
Figure 10	Analog Input Signal Connections.....	17
Figure 11	Jumper Locations	21
Figure 12	Run/Decelerate to Minimum Speed Switch.....	24
Figure 13	Quick Reversing Circuit Wiring.....	25
Figure 14	Multiple Fixed Speeds	34
Figure 15	Adjustable Speeds Using Potentiometers in Series.....	35
Figure 16	Independent Adjustable Speeds.....	36
Figure 17	Independent Adjustable Speeds with a Direction Switch	37
Figure 18	RUN/JOG Switch - Enable Connection.....	38
Figure 19	RUN/JOG Switch - Potentiometer Connection	39
Figure 20	Diagnostic LED Locations	41
Figure 21	Carrier Frequency Capacitor Location.....	47

Section 1. Variable Frequency Drives

The VFD6x3 Series drives are solid-state, variable frequency AC motor controls. They utilize a 115 or 230 VAC, 50/60 Hz, single phase input to operate any 208/230-volt, three-phase AC-induction or single-phase permanent split capacitor motor and can be user calibrated for 0 through 120 Hz output.

Many 3-phase inverter manufacturers claim that they can run single phase motors effectively. This is normally accomplished by wiring only 2 phases; however, this method may cause instabilities due to the lack of feedback from one of the motor connections. Furthermore, motor torque will be considerably reduced because the phases are 120° apart. Although the VFD uses this method of connection, its fundamental design enables it to operate efficiently under these conditions.

Although VFD inverters can operate over their full speed range, most motors will operate with constant torque over a 10:1 speed range (6 - 60 Hz), and constant horsepower above 60 Hz. Inverter-duty rated motors may operate satisfactorily over a 20:1 speed range. Some motors can be satisfactorily operated at speeds as low as 50 RPMs (50:1 speed range). Below 50 RPMs, some motors may show signs of “stepping” or “cogging” and may run warmer.

Although the control will allow a minimum frequency down to 0 Hz, the actual minimum frequency is dependent on the motor type and load. The motor may need to be derated for low frequency operation. Please contact the motor manufacture.

In addition to standard 3-phase induction motors, the following motor types may be used with a VFD:

- Permanent Split Capacitor (PSC)
- Shaded Pole
- AC Synchronous

Section 2. Specifications

<i>Model</i>	<i>Enclosure</i>	<i>Input Voltage (ADC)</i>	<i>Output Voltage (ADC)</i>	<i>Maximum Armature Current</i>	<i>HP Range</i>
VFD643-4	Plastic NEMA 4X	115 VAC 230 VAC	230 VAC	4.0	3/8 - 1
VFD603-5	Chassis	115 VAC 230 VAC	230 VAC	5.0	3/8 - 1 1/2
VFD643-5	Steel NEMA 4X	115 VAC 230 VAC	230 VAC	5.0	3/8 - 1 1/2
AC Line Voltage			115 or 230 VAC \pm 10%, 50/60 Hz, 1 ϕ		
AC Motor Voltage			230 VAC, 50/60 Hz, 1 ϕ or 3 ϕ		
Output Frequency Range					0 - 120 Hz
Adjustable Maximum Frequency Range					30 - 120 Hz
Standard Carrier Frequency					16 kHz
Acceleration Time Range					1 - 12 seconds
Deceleration Time Range					1 - 12 seconds
Braking Current					0-100% rated output
Braking Time					1 - 12 seconds
Analog Input Range (signal may be grounded or isolated)			0-5 VDC, 0-10 VDC, 4-20 mA		
Input Impedance (S1 to S2)					\sim 100K ohms
Vibration					0.5G maximum (0 - 50 Hz) 0.1G maximum (> 50 Hz)
Safety Certifications			UL/cUL Listed Equipment, File # E132235		
Ambient Temperature Range					10°C - 40°C

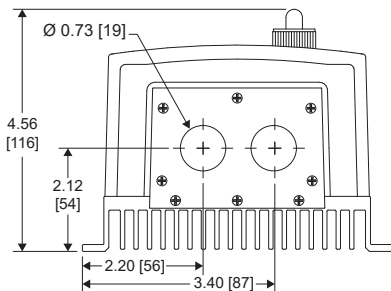
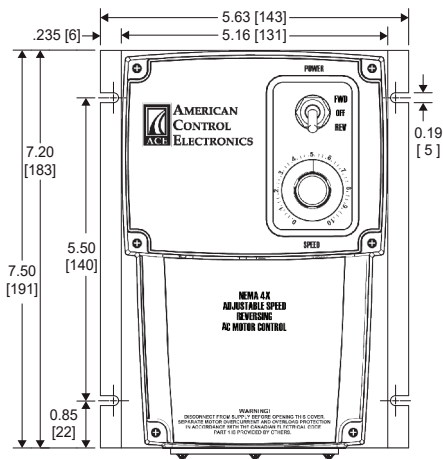

ALL DIMENSIONS IN INCHES [MILLIMETERS]

Figure 2. VFD643-4 Dimensions

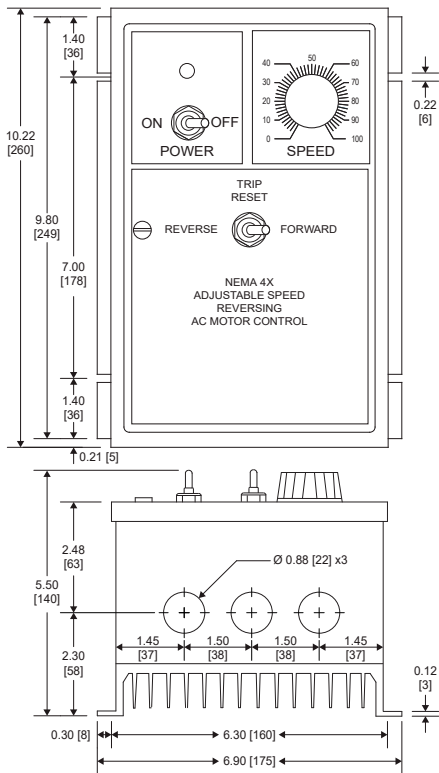

ALL DIMENSIONS IN INCHES [MILLIMETERS]

Figure 3. VFD643-5 Dimensions

Section 4. Installation



Do not install, rewire, or remove this control with input power applied. Failure to heed this warning may result in fire, explosion, or serious injury. Make sure you read and understand the Safety Precautions on page i before attempting to install this product.

Mounting

VFD603-5

- Drive components are sensitive to electrostatic discharge. Avoid direct contact with the circuit board. Hold the drive by the heat sink only.
- Protect the drive from dirt, moisture, and accidental contact.
- Provide sufficient room for access to the terminals and calibration trim pots.
- Mount the drive away from heat sources. Operate the drive within the specified ambient operating temperature range.
- Prevent loose connections by avoiding excessive vibration of the drive.
- Mount the drive with its board in vertical plane. Four 0.19" (5 mm) wide slots in the heat sink accept #8 pan head screws. Fasten either the large base or the narrow flange of the chassis to the subplate. Horizontal mounting may require de-rating of the drive. Horizontal mounting may require some derating of the maximum output current.
- The heat sink should be earth grounded. Use a star washer beneath the head of at least one of the mounting screws to penetrate the anodized surface and to reach bare metal.

Speed Adjust Potentiometer



Be sure that the potentiometer tabs do not make contact with the potentiometer's body. Grounding the input will cause damage to the drive.

If using a remote potentiometer with a chassis drive, mount the speed adjust potentiometer through a 0.38 in. (10 mm) hole with the hardware provided (Figure 4). Install the circular insulating disk between the panel and the 10K ohm speed adjust potentiometer.

Twist the speed adjust potentiometer wire to avoid picking up unwanted electrical noise. If the speed adjust potentiometer wires are longer than 18 in. (46 cm), use shielded cable. Keep the speed adjust potentiometer wires separate from power leads (L1, L2, U, V, W).

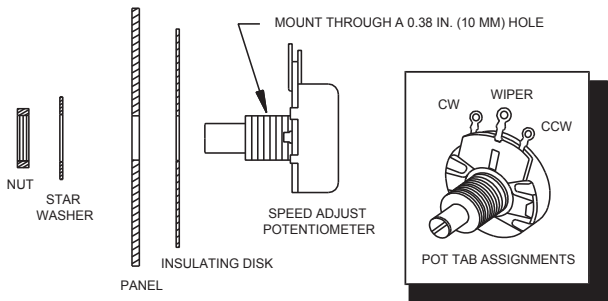

Figure 4. Speed Adjust Potentiometer

VFD643-4

NEMA 4X cased drives come with two 0.73 inch (18.5 mm) conduit knockout holes at the bottom of the case. The units may be mounted using the four 0.19 inch (5 mm) slotted holes on the heat sink.

1. Install the mounting screws in the four heat sink slotted holes.
2. For access to the terminal strip, remove the six phillips screws on the front cover.
3. Remove the five phillips screws on the bottom plate. **Do not remove the three screws securing the bottom plate to the heat sink.**
4. Set the POWER switch to the off position before applying AC line voltage.
5. Install conduit hardware through the 0.73 inch (18.5 mm) knockout holes. Connect external wiring to the terminal block.
6. Place the front cover back into place. Avoid pinching any wires between the front cover and the heat sink.
7. Reinstall the 6 screws on the front cover. **The two shorter screws are for the two lower holes of the front cover.** Reinstall the 5 screws on the bottom plate.

VFD643-5

NEMA 4X cased drives come with two 0.73 inch (18.5 mm) conduit knockout holes at the bottom of the case. The units may be mounted using the four 0.19 inch (5 mm) slotted holes on the attached heat sink. It is recommended that tape be applied to the backside of the conduit holes before knocking the two holes out to shield the drive from metal shavings. Surfaces should be cleaned of all metal shavings and other metal coating materials before installation.

1. Install the mounting screws in the four heat sink slotted holes.
2. For access to the terminal strip, remove the six phillips screws on the front cover.
3. Remove the five phillips screws on the bottom plate. **Do not remove the three screws securing the bottom plate to the heat sink.**
4. Set the POWER switch to the off position before applying AC line voltage.
5. Install conduit hardware through the 0.73 inch (18.5 mm) knockout holes. Connect external wiring to the terminal block.
6. Place the front cover back into place. Avoid pinching any wires between the front cover and the heat sink.
7. Reinstall the 6 screws on the front cover. **The two shorter screws are for the two lower holes of the front cover.** Reinstall the 5 screws on the bottom plate.

Wiring



Do not install, rewire, or remove this control with input power applied. Failure to heed this warning may result in fire, explosion, or serious injury.

Circuit potentials are at 115 or 230 VAC above ground. To prevent the risk of injury or fatality, avoid direct contact with the printed circuit board or with circuit elements.

Do not disconnect any of the motor leads from the drive unless power is removed or the drive is disabled. Opening any one motor lead while the drive is running may destroy the drive.

This product does not have internal solid state motor overload protection. It does not contain speed-sensitive overload protection, thermal memory retention or provisions to receive and act upon signal from remote devices for over temperature protection. If motor over protection is needed in the end-use product, it needs to be provided by additional equipment in accordance with NEC standards.

- Use 18 - 24 AWG wire for logic wiring. Use 14 - 16 AWG wire for AC line and motor wiring.

Shielding Guidelines



Under no circumstances should power and logic level leads be bundled together. Induced voltage can cause unpredictable behavior in any electronic device, including motor controls.

As a general rule, it is recommended to shield all conductors. If it is not practical to shield power conductors, it is recommended to shield all logic-level leads. If shielding of all logic-level leads is not practical, the user should twist all logic leads with themselves to minimize induced noise.

It may be necessary to earth ground the shielded cable. If noise is produced by devices other than the drive, ground the shield at the drive end. If noise is generated by a device on the drive, ground the shield at the end away from the drive. Do not ground both ends of the shield.

If the drive continues to pick up noise after grounding the shield, it may be necessary to add AC line filtering devices, or to mount the drive in a less noisy environment.

Logic wires from other input devices, such as motion controllers and PLL velocity controllers, must be separated from power lines in the same manner as the logic I/O on this drive.

Line Fusing

The drives should be fused for protection. Use fast acting fuses rated for 250 VAC or higher and 150% of maximum armature current. Fuse HOT L1 only when the line voltage is 115 VAC. Fuse both L1 and L2 when the line voltage is 230 VAC. Table 1 lists the recommended line fuse sizes.

Table 1. Recommended Line Fuse Sizes

<i>Drive</i>	<i>Single Phase Input Voltage (VAC)</i>	<i>Maximum Horsepower</i>	<i>AC Line Current (amps)</i>	<i>AC Line Fuse Size (amps)</i>
VFD643-4	115 / 230	1	14 / 7	15
VFD603-5	115 / 230	1 1/2	20 / 10	20
VFD643-5	115 / 230	1 1/2	20 / 10	20

Connections



Do not connect this equipment with power applied. Failure to heed this warning may result in fire, explosion, or serious injury.

Do not connect a 230 VAC line input when the drive is set for a 115 VAC input. This will result in severe damage to the motor and the drive, and can lead to explosion and/or injury. Check jumper settings before connecting the AC power input.

American Control Electronics strongly recommends the installation of a master power switch in the voltage input line, as shown in Figure 5. The switch contacts should be rated at a minimum of 200% of motor nameplate current and 250 volts. This switch is included with enclosed models.

AC Line Input

Connect the AC line power leads to terminals L1 and L2. American Control Electronics recommends the use of a single-throw, double-pole master power switch for chassis models. The switch should be rated at a minimum of 250 volts and 200% of motor current. Refer to Figure 5.

Jumpers JMP501 and JMP502 must be set for 115 or 230 VAC before power is applied. Refer to page 19.

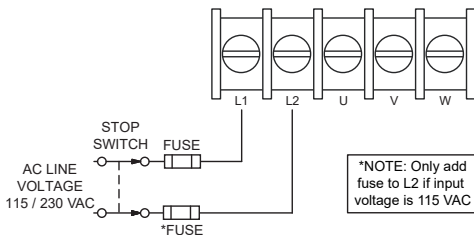

Figure 5. AC Line Connections

**WARNING!**

Caution should be taken when operating fan-cooled motors at low speeds because their fans may not move sufficient air to properly cool the motor. It is recommended to use “inverter-duty” rated motors when the speed range is beyond 10:1.

The following motor types MAY NOT be used:

- Split Phase
- Capacitor Start
- Repulsion Induction
- Series Universal AC/DC
- Any motor with a starting switch (centrifugal or relay) and/or a separate starting winding

Motor Connections (Single Phase Operation)

For single phase operation, connect the motor as shown in Figure 6. Ensure that the prewired capacitor and its associated motor coil are connected to terminals U and V as shown. This connection may be internal if using a 2-wire motor. If the motor has 3-leads, you may need to make this connection yourself.

To reverse a single phase split capacitor motor, connect the motor as shown in Figure 7. The motor run cap must be removed from the circuit.

Motor Connections (Three Phase Operation)

Connect the motor to terminals U, V, and W as shown in Figure 8.

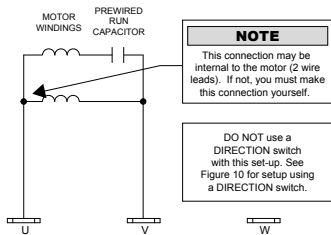

Figure 6. Single Phase Motor Connections

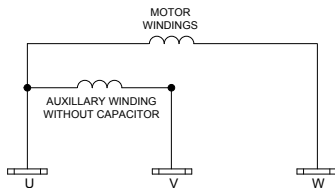

Figure 7. Single Phase Motor Connections - Reversing

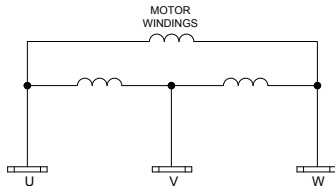

Figure 8. Three Phase Motor Connections

Speed Adjust Potentiometer

Use a 10K ohm, 1/4 W potentiometer for speed control. Connect the counter-clockwise end of the potentiometer to S1, the wiper to S2, and the clockwise end to S3. If the potentiometer works inversely of the desired functionality (e.g. to increase motor speed you must turn the potentiometer counterclockwise), power off the drive and swap the S1 and S3 connections. Refer to page 20 for jumper JMP504 and JMP505 settings.

Enable Switch

Connect a single-pole, single throw ENABLE switch between terminals E1 and E2. Open the switch to stop the motor. Close the switch to enable the drive and accelerate to set speed at a rate determined by the ACCEL trim pot. Refer to page 20 for coasting or braking the motor to a stop.

Direction Switch

Connect a single-pole, single throw DIRECTION switch between terminals E1 and D. Open the switch to run in the forward direction. Close the switch to run in the reverse direction. The motor will decelerate at a rate determined by the DECEL trim pot until it reaches zero speed, and will then accelerate in the opposite direction at a rate determined by the ACCEL trim pot. For quicker reversing, see page 25.

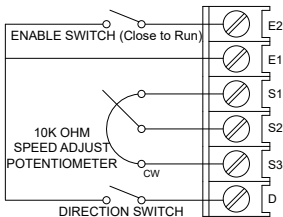

Figure 9. Potentiometer and Switch Connections

Analog Input Signal

Instead of using a speed adjust potentiometer, the drive may be wired to follow an analog signal that is non-isolated (grounded) or isolated (floating) from earth ground (Figure 11). Connect the signal common (-) to S1. Connect the signal reference (+) to S2. Make no connection to S3. A potentiometer can be used to scale the analog input voltage.

An analog signal range of 0–5 VDC, 0–10 VDC, or 4–20 mA is required to produce an output range of 0 - full speed. Refer to page 20 for jumper JMP504 and JMP505 settings.

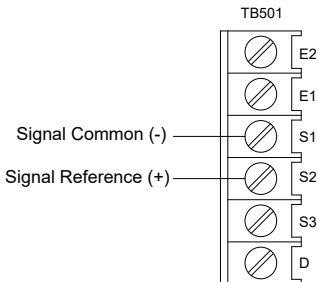

Figure 10. Analog Input Signal Connections

Section 5. Operation



Change jumper settings only when the drive is disconnected from AC line voltage. Make sure both switches are set to their correct position. Improper jumper settings may cause motor damage or result in bodily injury or loss of life.

Dangerous voltages exist on the drive when it is powered. BE ALERT. High voltages can cause serious or fatal injury. For your safety, use personal protective equipment (PPE) when operating this drive.

If the motor or drive does not perform as described, disconnect the AC line voltage immediately. Refer to the Troubleshooting section, page 42, for further assistance.

Before Applying Power

1. Verify that no foreign conductive material is present on the printed circuit board.
2. Ensure that all switches / jumpers are properly set.

Select Switches

AC Line Voltage Jumpers (JMP501 and JMP502)

The drive is equipped with a voltage doubling feature which converts a 115 VAC input into a 230 VAC output. If the input voltage is 115 VAC, jumper JMP502 for 115 VAC and place the U-shaped jumper on JMP501. The U-shaped jumper is shipped attached to terminal W.

If the input voltage is 230 VAC, jumper JMP502 for 230 VAC and leave JMP501 open.

Fault Reset Type Select (JMP503)

When the input voltage drops too low, a fault condition will occur. The drive will automatically disable the output and the FAULT LED will turn on. To have the the drive automatically run back to set speed after the the AC line has come back up, set jumper JMP503 to RESTART. To require the Enable switch to be toggled before running again, set JMP503 to UV TRIP.

Control Signal Selects (JMP504 and JMP505)

If using a 10k potentiometer or 0-5 VDC analog signal, jumper pins 1 & 2 on JMP504, and pin set 1 on JMP505.

If using a 0-10 VDC analog signal, jumper pins 1 & 2 on JMP504, and pin set 2 on JMP505.

If using a 4-20 mA analog signal, jumper pins 2 & 3 in JMP504, and pin set 3 on JMP505.

Stopping Method Select (JMP506)

To coast the motor to a stop when the Enable switch is opened, set jumper JMP506 to COAST. To brake the motor to a stop when the Enable switch is opened, jumper JMP506 to BRAKE. When set to BRAKE, the drive will inject a DC current into the motor to quickly decelerate the motor. The amount of DC current is determined by the BRAKE CURRENT trim pot and is applied for an amount of time set by the BRAKE TIME trim pot.

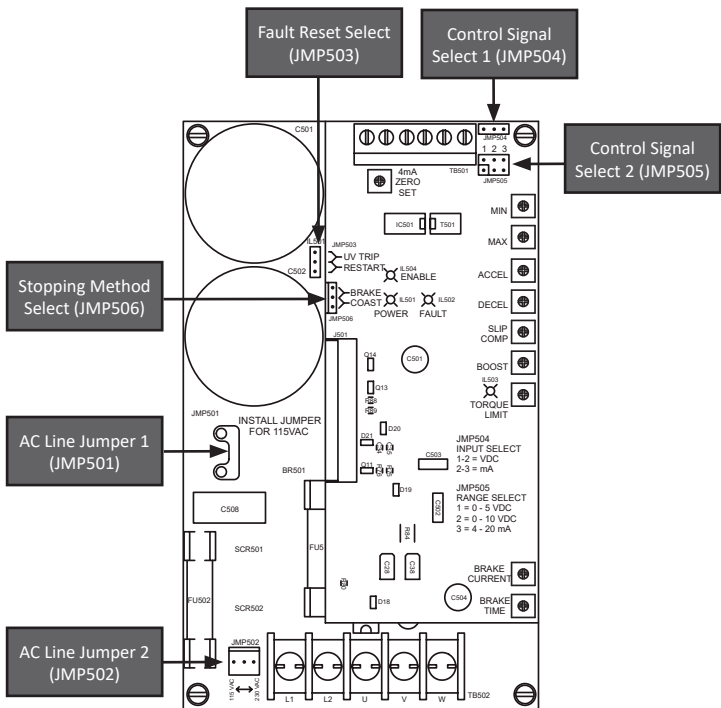

Figure 11. Jumper Locations

Startup

1. Turn the speed adjust potentiometer full counterclockwise (CCW) or set the analog signal to minimum.
2. Apply AC line voltage.
3. Slowly advance the speed adjust potentiometer clockwise (CW) or increase the analog signal. The motor slowly accelerates as the potentiometer is turned CW or as the input voltage signal is increased. Continue until the desired speed is reached.
4. Remove AC line voltage from the drive to coast the motor to a stop.

Starting and Stopping Methods



DC injection braking, coasting to a stop, or decelerating to minimum speed is recommended for frequent starts and stops. Do not use any of these methods for emergency stopping. They may not stop a drive that is malfunctioning. Removing AC line power (both lines) is the only acceptable method for emergency stopping.

For this reason, American Control Electronics strongly recommends installing an emergency stop switch on both AC line inputs (see Figure 5 on page 13).

Frequent starting and stopping can produce high torque. This may cause damage to motors, especially gearmotors that are not properly sized for the application.

Automatic Restart Upon Power Restoration

All drives automatically run to set speed when power is applied and the enable is closed.

Line Starting and Stopping

Line starting and stopping (applying and removing AC line voltage) is recommended for infrequent starting and stopping of a drive only. When AC line voltage is applied to the drive, the motor accelerates to the speed set by the speed adjust potentiometer or analog signal. When AC line voltage is removed, the motor coasts to a stop.

Decelerating to Zero Speed

The switch shown in Figure 12 may be used to decelerate a motor to zero speed. The DECEL trim pot setting determines the rate at which the drive decelerates. By opening the switch, the motor accelerates to set speed at a rate determined by the ACCEL trim pot setting.

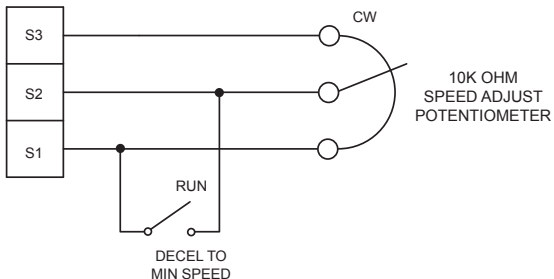

Figure 12. Run/Decelerate to Minimum Speed Switch

Quick Reversing

To reverse the direction of the motor shaft rotation, install a DPDT center off switch as shown below (Figure 13). The drive will brake the motor before reversing, so there is no need to wait for the motor to coast to a stop before changing direction.

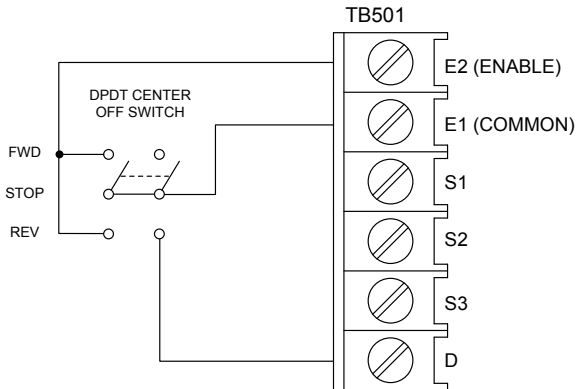

Figure 13. Quick Reversing Circuit Wiring

Section 6. Calibration



Dangerous voltages exist on the drive when it is powered. When possible, disconnect the voltage input from the drive before adjusting the trim pots. If the trim pots must be adjusted with power applied, use insulated tools and the appropriate personal protection equipment. **BE ALERT.** High voltages can cause serious or fatal injury.

VFD643 series drives have user-adjustable trim pots. Each drive is factory calibrated to its maximum current rating. Readjust the calibration trim pot settings to accommodate lower current rated motors.

All adjustments increase with CW rotation, and decrease with CCW rotation. Use a non-metallic screwdriver for calibration. Each trim pot is identified on the printed circuit board.

4-20 mA Offset (ZERO SET)

The ZERO SET setting adjusts out any motor drifting from the 4 mA signal being converted into a voltage signal in the drives logic circuitry. ZERO SET only needs to be calibrated if using a 4-20 mA analog signal. To calibrate ZERO SET:

1. Set the drive to follow a potentiometer signal by jumpering pins 1 & 2 on JMP504 and pin set 1 on JMP505.
2. Place a jumper (short) across terminals S1 and S2. The 4-20 mA analog signal should not be connected to the drive at this time.
3. Apply power and adjust the MIN trim pot until the motor is just at the threshold of rotation.
4. Remove power and the jumper between terminals S1 and S2.
5. Set the drive to follow a 4-20 mA signal by jumpering pins 2 & 3 on JMP504 and pin set 3 on JMP505.
6. Connect the 4-20 mA signal common (negative) to terminal S1. Connect the reference (positive) to terminal S2.
7. Apply 4 mA and adjust the ZERO SET trim pot until the motor is again just at the threshold of rotation.

Minimum Speed (MIN)

The MIN setting determines the minimum motor speed (voltage/frequency) when the speed adjust potentiometer or input signal is set for minimum speed.

To calibrate MIN:

1. Set the MIN trim pot full CCW.
2. Set the speed adjust potentiometer or analog signal for minimum speed.
3. Adjust MIN until the desired minimum speed is reached.

Maximum Speed (MAX)

The MAX setting determines the maximum motor speed (voltage/frequency) when the speed adjust potentiometer or input signal is set for maximum speed.

To calibrate MAX:

1. Set the MAX trim pot full CCW.
2. Set the speed adjust potentiometer or analog signal for maximum speed.
3. Adjust MAX until the desired maximum speed is reached.

Acceleration (ACCEL)

The ACCEL setting determines the time the motor takes to ramp to a higher speed. See Specifications on page 1 for approximate acceleration times. ACCEL is factory set for the shortest acceleration time (full CCW).

To set the acceleration time:

1. Set the speed adjust potentiometer or analog signal for minimum speed. The motor should run at minimum speed.
2. Set the speed adjust potentiometer or analog signal for maximum speed. Measure the time it takes the motor to go from minimum to maximum speed.
3. If the time measured in step 2 is not the desired acceleration time, turn the ACCEL trim pot CW for a longer acceleration time or CCW for a shorter acceleration time. Repeat steps 1 through 2 until the acceleration time is correct.

Deceleration (DECEL)

The DECEL setting determines the time the motor takes to ramp to a lower speed. See Specifications on page 1 for approximate deceleration times. DECEL is factory set for the shortest deceleration time (full CCW).

To set the deceleration time:

1. Set the speed adjust potentiometer or analog signal for maximum speed. The motor should run at maximum speed.
2. Set the speed adjust potentiometer or analog signal for minimum speed. Measure the time it takes the motor to go from maximum to minimum speed.
3. If the time measured in step 2 is not the desired deceleration time, turn the DECEL trim pot CW for a longer deceleration time or CCW for a shorter deceleration time. Repeat steps 1 through 2 until the deceleration time is correct.

Torque (TORQUE LIMIT)



TORQUE LIMIT should be set to 120% of motor nameplate current rating. Continuous operation beyond this rating may damage the motor. If you intend to operate beyond the rating, contact your American Control Electronics representative for assistance.

The TORQUE LIMIT setting determines the maximum torque for accelerating and driving the motor.

To calibrate TORQUE LIMIT:

1. With the power disconnected from the drive, connect a true RMS meter in series with one of the motor leads.
2. Set the TORQUE LIMIT trim pot to minimum (full CCW).
3. Set the speed adjust potentiometer full CW or analog signal to maximum speed.
4. Carefully lock the motor shaft. Be sure that the motor is firmly mounted.
5. Apply line power. The motor should be stalled.
6. Slowly adjust the TORQUE LIMIT trim pot CW until the motor current is 120% of motor rated current.
7. Turn the speed adjust potentiometer CCW or decrease the analog signal.
8. Remove line power.
9. Remove the stall from the motor.
10. Remove the meter if it is no longer needed.

Boost (BOOST)

The BOOST trim pot is used to increase motor torque at low speeds. The minimum setting is sufficient for most applications and does not need to be adjusted. If the motor stalls or runs erratically at very low speeds (below 10 Hz), the boost trim pot may need adjustment. To calibrate BOOST:

1. Run the motor at the lowest continuous frequency/speed required.
2. Monitor the motor phase current with a true RMS meter while very slowly turning the BOOST trim pot CW until the motor operates properly, or 100% of the motor nameplate current is reached.

Use the absolute minimum amount of BOOST necessary to achieve proper motor operation. Improper use of the BOOST feature may cause motor and/or drive overheating and failure.

Slip Compensation (SLIP COMP)

Slip compensation is used to minimize the normal speed changes occurring in an induction motor from no load to full load conditions. To calibrate SLIP COMP:

1. Using a tachometer to measure the motor shaft RPM, run the motor unloaded at an RPM that is the most common desired RPM for the application.
2. Without changing the commanded speed, apply a full load to the motor. Adjust the SLIP COMP trim pot until the fully loaded RPM matches the desired unloaded RPM in step 1.
3. Steps 1 and 2 may need to be repeated several times to reach the desired accuracy that is required.

DC Injection Braking Current (BRAKE CURRENT)



DC Injection Braking causes high spikes of current on the AC line and in the AC motor. These spikes, if too large or too frequency, may cause damage to the motor and / or drive. Calibrate the BRAKE CURRENT trim pot only to the level needed for the application.

If JMP506 is set to BRAKE, the drive will inject a DC current into the motor to quickly bring it to a stop. The BRAKE CURRENT trim pot only needs to be calibrated if JMP506 is set to BRAKE. To calibrate BRAKE CURRENT:

1. Make sure JMP506 is set to BRAKE, the Enable switch is open, and the AC line is off.
2. Set the BRAKE TIME trim pot fully clockwise and the BRAKE CURRENT trim pot fully counterclockwise.
3. Set the speed adjust potentiometer or analog signal for full speed.
4. Apply AC power and close the Enable switch to run the motor.
5. Open the Enable switch to brake the motor to a stop. If the motor does not brake quickly enough, turn the BRAKE CURRENT trim pot CW.
6. Close the Enable switch to run the motor again.
7. Repeat steps 5 and 6 until the BRAKE CURRENT trim pot is set high enough to allow enough current for the braking demanded by the application.

DC Injection Braking Time (BRAKE TIME)

The BRAKE TIME trim pot determines how long the DC injection current set by the BRAKE CURRENT trim pot is applied to motor. The BRAKE CURRENT trim pot must be calibrated before the BRAKE TIME trim pot. To calibrate BRAKE TIME:

1. Set the BRAKE TIME trim pot fully clockwise.
2. Run the motor. Open the Enable switch to brake the motor to a stop. Make note of how long it takes the motor to stop.
3. Turn the BRAKE TIME trim pot slightly counterclockwise.
4. Repeat steps 2 and 3 until the BRAKE TIME trim pot begins to effect how long it takes the motor to stop. The BRAKE TIME should be set at the threshold of where the settings begins to effect the braking time.

The result should be that the DC injection current is only applied for the amount of time necessary for braking the motor to a stop. If not applied long enough, the motor will not stop as fast. If applied too long, it is not healthy for the motor.

Section 7. Application Notes

Multiple Fixed Speeds

Replace the speed adjust potentiometer with a series of resistors with a total series resistance of 10K ohms (Figure 14). Add a single pole, multi-position switch with the correct number of positions for the desired number of fixed speeds.

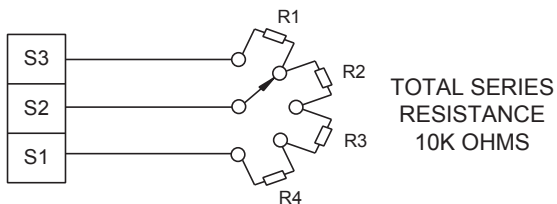

Figure 14. Multiple Fixed Speeds

Adjustable Speeds Using Potentiometers In Series

Replace the speed adjust potentiometer with a single pole, multi-position switch, and two or more potentiometers in series with a total series resistance of 10K ohms. Figure 15 shows a connection for high and low speed adjust potentiometers.

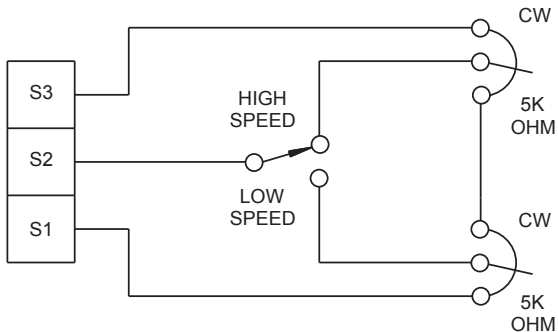

Figure 15. Adjustable Speeds Using Potentiometers In Series

Independent Adjustable Speeds

Replace the speed adjust potentiometer with a single pole, multi-position switch, and two or more potentiometers in parallel, with a total parallel resistance of 10K ohms. Figure 16 shows the connection of two independent speed adjust potentiometers that can be mounted at two separate operating stations.

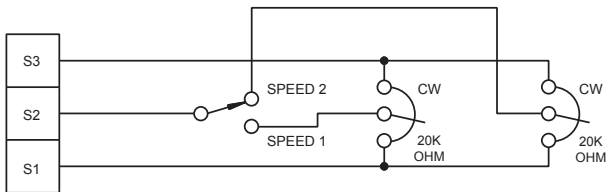

Figure 16. Independent Adjustable Speeds

Independent Adjustable Speeds with Direction Switch

Replace the speed adjust potentiometer with two single-pole, double throw switches, and two potentiometers in parallel with a total parallel resistance of 10K ohms. Figure 17 shows the connection of two independent speed adjust potentiometers that can be mounted at two separate operating stations.

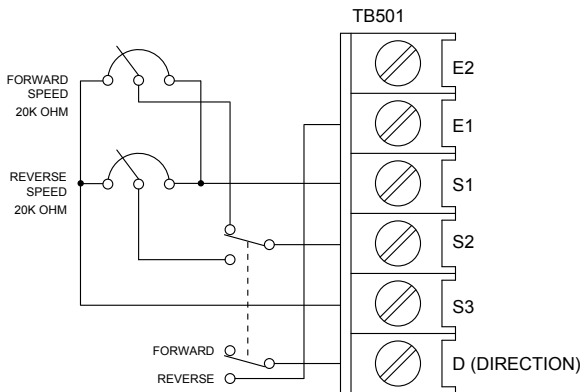

Figure 17. Independent Adjustable Speeds with a Direction Switch

RUN/JOG Switch - Enable Connection

Connect the RUN/JOG switch and the JOG pushbutton as shown in Figure 18. When the RUN/JOG switch is set to JOG, the motor coasts to zero speed. Press the JOG pushbutton to jog the motor. Return the RUN/JOG switch to RUN for normal operation.

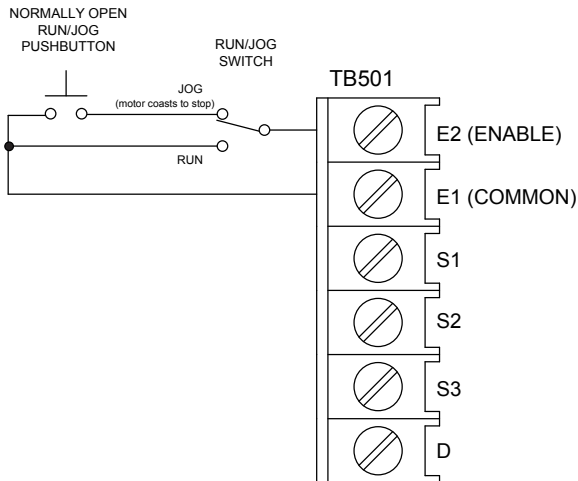

Figure 18. RUN/JOG Switch - Enable Connection

RUN/JOG Switch - Potentiometer Connection

Connect the RUN/JOG switch and the JOG pushbutton as shown in Figure 19. When the RUN/JOG switch is set to JOG, the motor decelerates to zero speed at a rate determined by the DECEL trim pot. Press the JOG pushbutton to jog the motor. Return the RUN/JOG switch to RUN for normal operation.

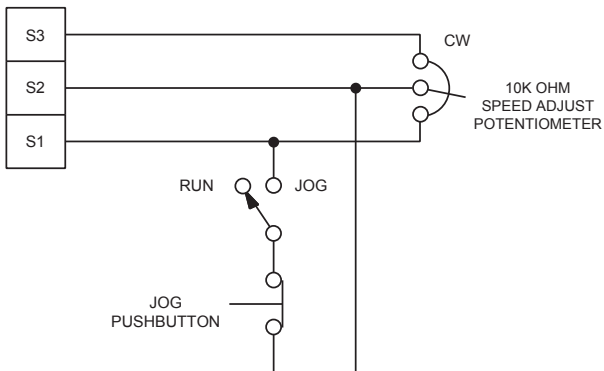

Figure 19. RUN/JOG Switch - Connection to Speed Adjust Potentiometer

Section 8. Diagnostic LEDs

VFD643 series drives are equipped with three diagnostic LEDs:

- Power (POWER): Green LED lights whenever AC line voltage is applied to the drive.
- Enable (ENABLE): Red LED lights whenever the Enable switch is closed and motor has the potential to run.
- Torque Limit (TORQUE LIMIT): Yellow LED lights whenever the drive reaches torque limit.
- Fault (FAULT): Red LED lights whenever one of the following conditions has occurred.
 1. Undervoltage: DC bus voltage dropped below 200 VDC.
 - 93.5 VAC rms with a 115 VAC line.
 - 187 VAC rms with a 230 VAC line.
 2. Overvoltage: DC bus voltage exceeded 400 VDC.
 - 152.5 VAC rms with a 115 VAC line.
 - 302 VAC rms with a 230 VAC line.
 3. Instantaneous Overcurrent Trip: Inverter output current has exceeded safe levels. Output current was 250% of drive rating.

To remove a fault condition, the enable must be cycled. Cycling the AC line power will remove a fault as well, but the capacitors must completely discharge before re-applying power for the fault to clear.

Refer to Figure 21 on page 41 for LED locations.

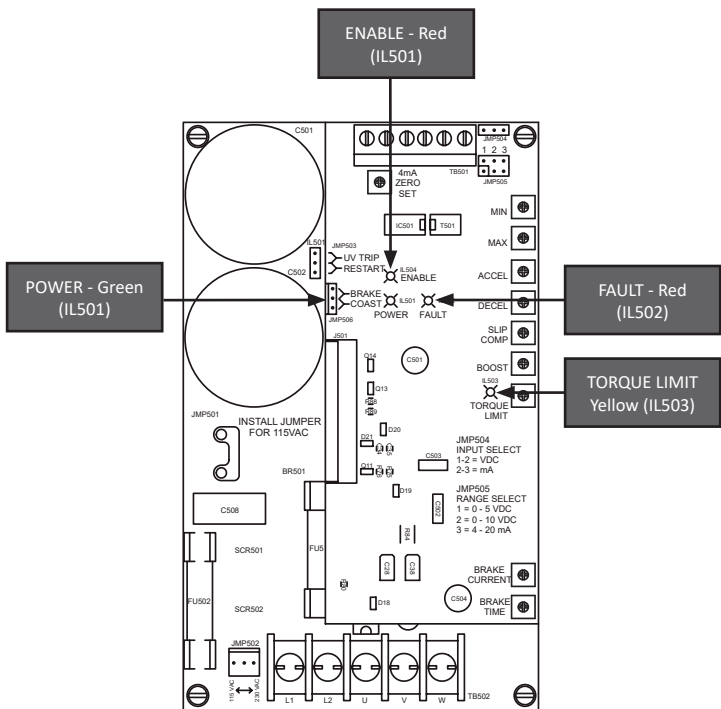

Figure 20. Diagnostic LED Locations

Section 9. Troubleshooting



Dangerous voltages exist on the drive when it is powered. When possible, disconnect the drive while troubleshooting. High voltages can cause serious or fatal injury.

Before Troubleshooting

Perform the following steps before starting any procedure in this section:

1. Disconnect AC line voltage from the drive.
2. Check the drive closely for damaged components.
3. Check that no conductive or other foreign material has become lodged on the printed circuit board.
4. Verify that every connection is correct and in good condition.
5. Verify that there are no short circuits or grounded connections.
6. Check that the jumper settings are correctly set.
7. Check that the drive's rated output is consistent with the motor ratings.

For additional assistance, contact your local American Control Electronics distributor or the factory direct.

PROBLEM	POSSIBLE CAUSE	SUGGESTED SOLUTIONS
Line fuse blows.	1. Line fuse is the wrong size.	1. Check that the line fuse is correct for the motor size.
	2. Motor cable or armature is shorted to ground.	2. Check motor cable for shorts.
	3. Nuisance tripping caused by a combination of ambient conditions and high-current spikes (i.e. reversing).	3. Add a blower to cool the drive components, decrease TORQUE LIMIT settings, resize motor and drive for actual load demand, or check for incorrectly aligned mechanical components or "jams". See page 30 for information on adjusting the TORQUE LIMIT trim pot.
Line fuse does not blow, but the motor does not run.	1. Speed adjust potentiometer or analog input signal is set to zero speed.	1. Increase the speed adjust potentiometer setting or analog input signal.
	2. Speed adjust potentiometer or analog input signal is not properly connected to drive input; connections are open.	2. Check connections to input. Verify that connections are not open.
	3. S2 is shorted to S1.	3. Remove the short.
	4. Drive is in torque limit.	4. Verify that the motor is not jammed. Increase TORQUE LIMIT setting if set too low.
	5. Drive is in a FAULT condition.	5. Disable and then re-enable drive.
	6. Drive is disabled.	6. Make sure there is a short between terminals COM and EN.
	7. Drive is not receiving AC line voltage.	7. Apply AC line voltage.
	6. Motor is not connected.	6. Remove power. Connect the motor to U, V, and W. Reapply power.

PROBLEM	POSSIBLE CAUSE	SUGGESTED SOLUTIONS
Motor runs too slow or too fast at set speed.	1. MAX trim pot is not calibrated correctly.	1. Calibrate the MAX trim pot (page 28).
Motor will not reach the desired speed.	1. MAX setting is too low.	1. Increase MAX setting (page 28).
	2. Nominal input voltage may be too low for motor.	2. Compare motor voltage to input voltage; replace motor is necessary.
	3. Motor is overloaded.	3. Check motor load. Resize the motor if necessary.
Motor pulsates or surges under load.	1. Motor “bouncing” in and out of torque limit.	1. Make sure the motor is not undersized for load; adjust TORQUE LIMIT setting CW (page 30).
Motor does not reverse.	1. Defective DIRECTION switch connection.	1. Check DIRECTION switch connection.
	2. Reversing wiring not working properly.	2. Check reversing circuit by shorting TB501 D terminal and EN terminal with jumper wire.
TORQUE LIMIT is unsatisfactory at high speeds.	1. TORQUE LIMIT set too low.	1. Check TORQUE LIMIT setting (page 30).
	2. Load may exceed rating of motor/drive.	2. “Fix” load (i.e., straighten mounting, coupling, etc.); or replace motor and drive with motor and drive rated for higher horsepower.
	3. Nominal input voltage may be too low for motor.	3. Compare motor voltage to input voltage. Replace motor if necessary.

Section 10. Accessories & Replacement Parts

Displays

Closed Loop..... OLD100-1

Open Loop..... CLD100-1

Kits

Potentiometer & Connector

Pot Kit 202-0113

Carrier Frequency Capacitor Kit

Capacitor Kit 202-0108

Section 11. Optional C510 Capacitor Kit

In some applications, lower carrier frequency reduces switching losses and increases bearing life in some motors. American Control Electronics provides an optional capacitor kit for lowering the carrier frequency.

The default carrier frequency on a VFD643 series control is 16 kHz. Using one of the capacitors supplied in kit 202-0108, the carrier frequency can be lowered to a range of 4 kHz to 12 kHz.

Note: Audible noise will increase as carrier frequency is lowered.

To lower the carrier frequency on a VFD643 series control, install one of the following 2-pin capacitors (C510) on the bottom board. Refer to Figure 22 on page 47.

Table 2. 202-0108 Capacitor Values and Carrier Frequency

<i>Frequency</i>	<i>Label on Capacitor</i>	<i>Value</i>
12 kHz	3n3J	0.0033 μ F
10 kHz	6n8	0.0068 μ F
8 kHz	10n	0.01 μ F
4 kHz	33n	0.033 μ F

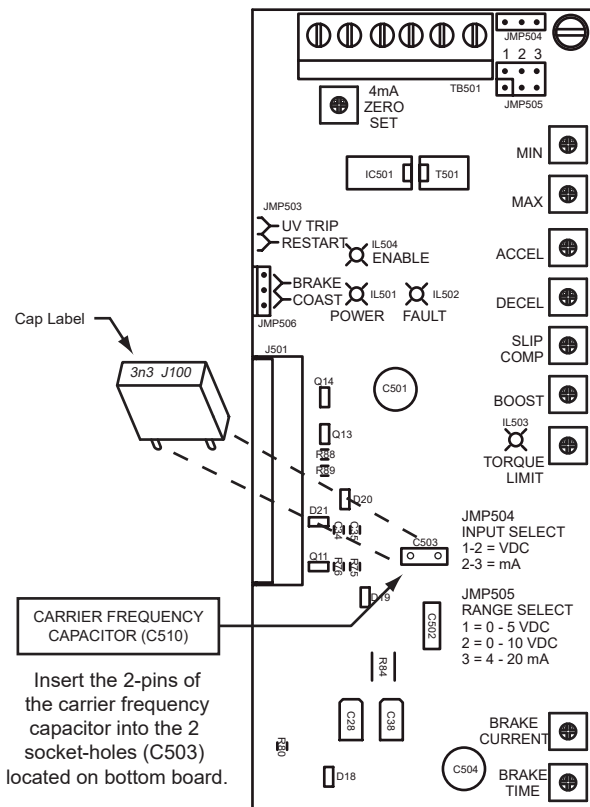

Figure 21. Carrier Frequency Capacitor Location

Unconditional Warranty

A. Warranty

American Control Electronics warrants that its products will be free from defects in workmanship and material for twelve (12) months or 3000 hours, whichever comes first, from date of manufacture thereof. Within this warranty period, American Control Electronics will repair or replace, at its sole discretion, such products that are returned to American Control Electronics, 14300 De La Tour Drive, South Beloit, Illinois 61080 USA.

This warranty applies only to standard catalog products, and does not apply to specials. Any returns of special controls will be evaluated on a case-by-case basis. American Control Electronics is not responsible for removal, installation, or any other incidental expenses incurred in shipping the product to and from the repair point.

B. Disclaimer

The provisions of Paragraph A are American Control Electronics's sole obligation and exclude all other warranties of merchantability for use, expressed or implied. American Control Electronics further disclaims any responsibility whatsoever to the customer or to any other person for injury to the person or damage or loss of property of value caused by any product that has been subject to misuse, negligence, or accident, or misapplied or modified by unauthorized persons or improperly installed.

C. Limitations of Liability

In the event of any claim for breach of any of American Control Electronics's obligations, whether expressed or implied, and particularly of any other claim or breach of warranty contained in Paragraph A, or of any other warranties, expressed or implied, or claim of liability that might, despite Paragraph B, be decided against American Control Electronics by lawful authority, American Control Electronics shall under no circumstances be liable for any consequential damages, losses, or expenses arising in connection with the use of, or inability to use, American Control Electronics's product for any purpose whatsoever.

An adjustment made under warranty does not void the warranty, nor does it imply an extension of the original 12-month warranty period. Products serviced and/or parts replaced on a no-charge basis during the warranty period carry the unexpired portion of the original warranty only.

If for any reason any of the foregoing provisions shall be ineffective, American Control Electronics's liability for damages arising out of its manufacture or sale of equipment, or use thereof, whether such liability is based on warranty, contract, negligence, strict liability in tort, or otherwise, shall not in any event exceed the full purchase price of such equipment.

Any action against American Control Electronics based upon any liability or obligation arising hereunder or under any law applicable to the sale of equipment or the use thereof, must be commenced within one year after the cause of such action arises.



VFD603-5



VFD643-4



VFD643-5



www.americancontrolelectronics.com

14300 DE LA TOUR DRIVE
SOUTH BELOIT, IL 61080
(844) 262-6875 (AMCNTRL)

MAN-0029 Rev 0