

# AREA SENSOR BW SERIES

M A N U A L



Thank you very much for selecting Autonics products.  
For your safety, please read the following before using.

## Caution for your safety

- Please keep these instructions and review them before using this unit.
- Please observe the cautions that follow:
  - Warning** Serious injury may result if instructions are not followed.
  - Caution** Product may be damaged, or injury may result if instructions are not followed.
- The following is an explanation of the symbols used in the operation manual.
  - Warning**: Injury or danger may occur under special conditions.

### Warning

- This unit is not safety sensor purposed on saving life, protecting damages of asset or hearing body from dangerous parts of mechanical equipment, but it is the sensor detecting a normal object or irruption into working area without safety.
- Please, don't use it as safety equipment for the cutter or press.
- This unit doesn't follow any safety standard in the world.
- Please, check the safety standard of the country used.
- Please, note that we don't take any responsibilities when the problem related to overseas' rules or product liability(PL) is happened by using as follows:
  - Safety equipment for protecting a hand or other parts of worker at dangerous area.
  - Interlock on mechanical equipment.
  - Safety sensor on mechanical equipment for stopping it when detecting a hand or other parts of worker.
  - Detector for detecting a hand or other parts of worker at dangerous area and controlling door or window.

### Caution

- Please, don't do wiring in power ON. Please, use in specifications.
- Please, use in specifications. It may cause malfunction or life cycle shorter.
- Please, earth F.G.(Frame Ground) terminal when supplying power by switching power.
- Please, avoid fluorescent light with high frequency, high speed start or signal light affecting to detection ability.
- It may be unavailable to cut off the light by reflecting from the parts when installing it in 0.5m from wall or flat parts. Please, keep < Installation >.
- It may cause malfunction from interference when using them closely in parallel. Please, keep < Installation >.
- Please, install emitter and receiver in same direction. Light beam emitting will not be transferred to receiver if installed in opposite direction.
- Please, avoid a large vibrating area. It may cause a fire and malfunction.
- In cleaning the unit, do not use water or an oil-based detergent. It may cause an electric shock or fire.
- Please make power and output line as short as possible as it may cause malfunction by surges etc. if the lines is long. (Max. 30m)

## Ordering information

BW 20 - 08 P	Solid state output	P	NPN open collector output
			PNP open collector output
	Number of optical axes	04~48pcs	
	Optical axis pitch	20 20mm Pitch	
		40 40mm Pitch	
	Series		

## Structure

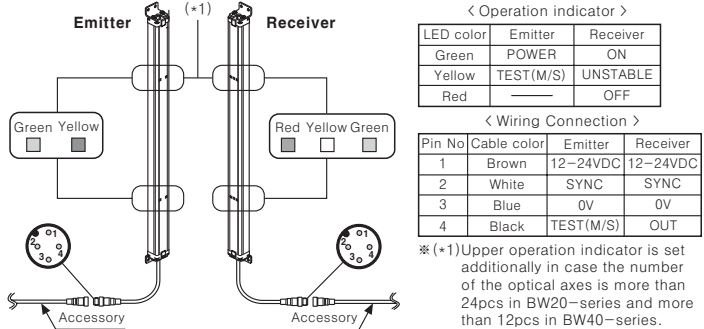

## Functions

- Light emitted stop function(External diagnosis function)**  
Light emitted will be stopped and yellow LED is flickered if supplying 0V to test input on the emitter. It is for checking malfunction of the sensors during TEST input on the emitter is 0V. (Control output of the receiver is OFF as it becomes light cut off when the light emitted is stopped)
- Control output pulse by TEST input**  
Normal:  $T_1, T_2 > 50ms$   
Abnormal:  $T_2 > 20ms$
- Connections for TEST input**  
For contact relay or For solid state relay

### Self-diagnosis function

- Control output will be OFF and operating indicator is ON when malfunction is checked by self-diagnosis regularly in normal operation.
- Diagnosis items**
  - Emitter: ① Break of light emitting element ② Break of light emitting circuit
  - Receiver: ① Break of light receiving circuit ② Break of output circuit

### Interference protection function

- In case of using 2pcs of sensor in parallel in order to extend detecting width the detection will be failure because as light interference. This function is to avoid the light interference as operating a sensor in MASTER and another sensor in SLAVE to protect these kinds of failures.

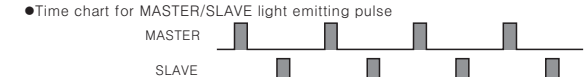

### MASTER/SLAVE connections

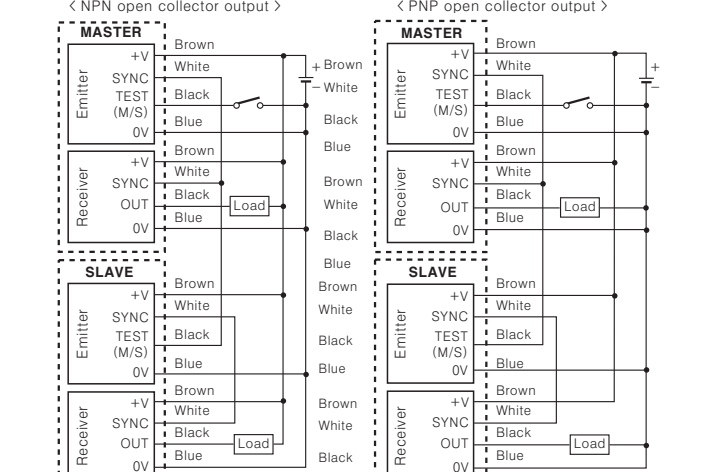

\* Please, connect "M/S" of SLAVE emitter to "SYNC" of MASTER.  
\* The above specification are changeable without notice anytime.

## Specifications

Model	BW20-□(P)	BW40-□(P)
Detecting type	Through-beam	
Detecting distance	0.1 ~ 7m	
Detecting target	Opaque materials of min. $\phi 30mm$	Opaque materials of min. $\phi 50mm$
Optical axis pitch	20mm	40mm
Number of optical axes	8~48	4~24
Detecting width	140~940mm	120~920mm
Pointing angle	Within $\pm 5^\circ$ (At over 3m detecting distance)	
Power supply	12~24VDC $\pm 10\%$ (Ripple P-P: Max. 10%)	
Reverse power protection circuit	Built in	
Current consumption	Emitter: Max. 80mA, Receiver: Max. 80mA	
Control output	NPN open collector output $\Rightarrow$ Load voltage: Max. 30VDC, Load current: Max. 100mA, Residual voltage: Max. 1V PNP open collector output $\Rightarrow$ Load current: Max. 100mA, Output voltage: Min. (Power supply-2.5)V	
Operation mode	Light ON only	
Short-circuit protection	Built-in	
Response time	Min. 12ms	
Light source	Infrared LED(modulated)	
Synchronization type	Timing method by synchronous line	
Self-diagnosis	Ambient light monitoring, Emitter/Receiver light circuit monitoring, Output circuit monitoring	
Interference protection	Interference protection by master/slave function	
Ambient temperature	-10 to +55°C (non-freezing condition)	
Storage temperature	-20 ~ +60°C	
Ambient humidity	35 ~ 85%RH	
Storage humidity	35 ~ 85%RH	
Ambient illumination	Sunlight: Max. 11,000lx, Incandescent lamp: Max. 3,000lx The square wave noise by the noise simulator (Voltage: $\pm 240V$ , Period: 10ms, Pulse width: 1 $\mu s$ )	
Noise strength	1,000VAC 50/60Hz for 1minute	
Dielectric strength	Min. 20M $\Omega$ (500VDC)	
Insulation resistance	1.5mm amplitude at frequency of 10 to 55Hz in each of X, Y, Z directions for 2 hours	
Vibration	500m/s <sup>2</sup> (50G) in X, Y, Z directions for 3 times	
Shock Protection	IP65(IEC standard)	
Material	Body: Aluminum Cover, Lens: Acril	
Accessory	Bracket A: 4EA, Bracket B: 4EA, Bolt: 8EA	
Net weight	Approx. 1.4kg(For 48 optical axes)	

## Input/Output circuit and connection diagram

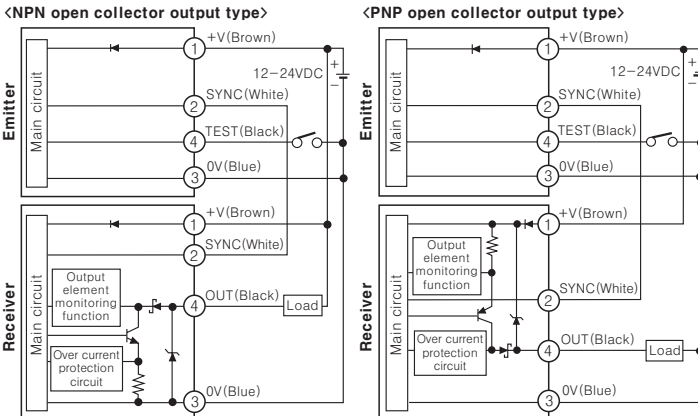

## Operating mode

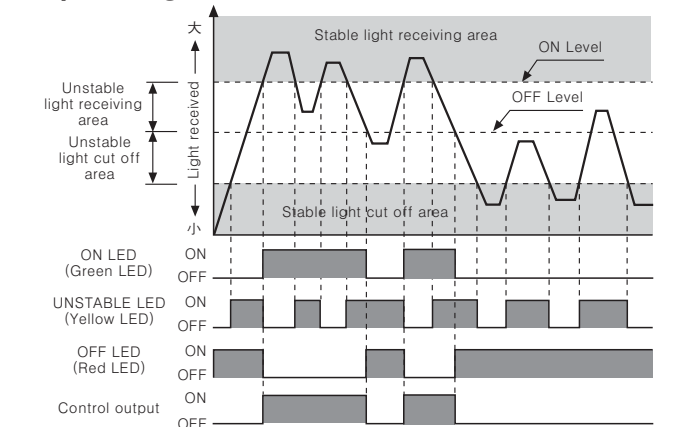

## Connecting cable

\* Connecting cable is optional and sold in a set(2pcs).

Model	Cable length (L)	Connector color
CID4-3	3m	Emitter: Black Receiver: Gray
CID4-5	5m	
CID4-7	7m	
CID4-10	10m	

## Installations

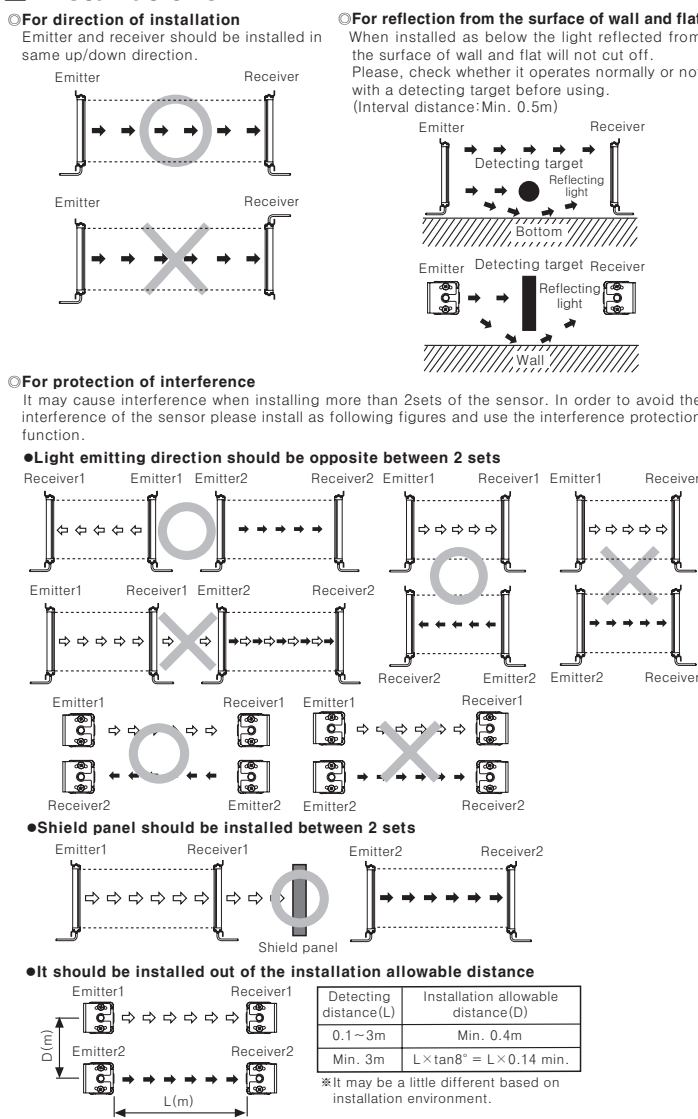

## Dimensions

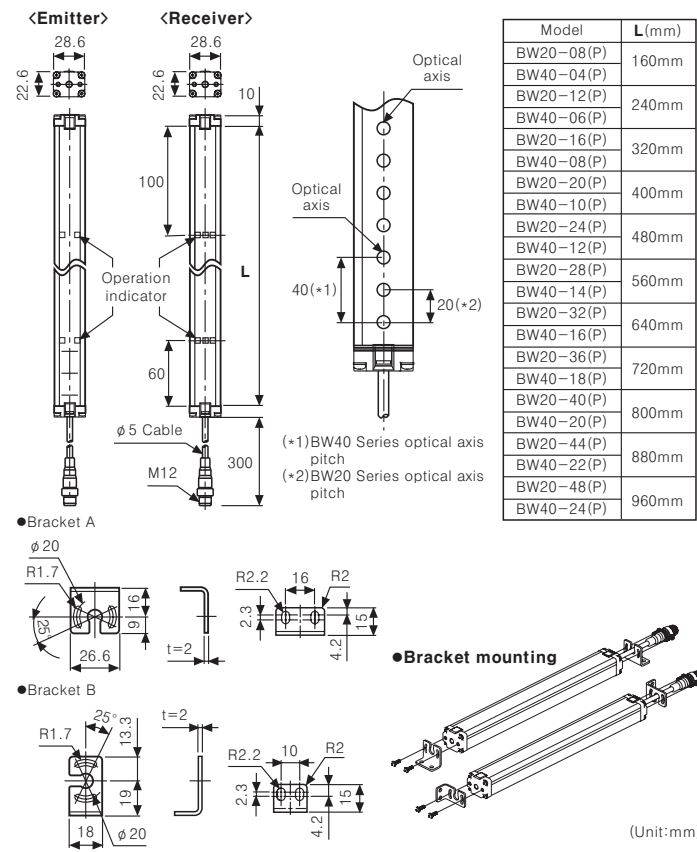

## Optical axis pitch/Number of optical axes/ Detecting width

Model	Optical axis pitch
BW20-□(P)	20mm
BW40-□(P)	40mm

Model	Number of optical axes	Detecting width	Model	Number of optical axes	Detecting width
BW20-08(P)	8pcs	140mm	BW40-04(P)	4pcs	120mm
BW20-12(P)	12pcs	220mm	BW40-06(P)	6pcs	200mm
BW20-16(P)	16pcs	300mm	BW40-08(P)	8pcs	280mm
BW20-20(P)	20pcs	380mm	BW40-10(P)	10pcs	360mm
BW20-24(P)	24pcs	460mm	BW40-12(P)	12pcs	440mm
BW20-28(P)	28pcs	540mm	BW40-14(P)	14pcs	520mm
BW20-32(P)	32pcs	620mm	BW40-16(P)	16pcs	600mm
BW20-36(P)	36pcs	700mm	BW40-18(P)	18pcs	680mm
BW20-40(P)	40pcs	780mm	BW40-20(P)	20pcs	760mm
BW20-44(P)	44pcs	860mm	BW40-22(P)	22pcs	840mm
BW20-48(P)	48pcs	940mm	BW40-24(P)	24pcs	920mm

## Operation indicator

Item	Emitter		Receiver		Control output
	Indicator Green	Indicator Yellow	Indicator Green	Indicator Red	
Power supply	ON	OFF	ON	OFF	ON
MASTER operation	ON	OFF	ON	OFF	ON
SLAVE operation	ON	OFF	ON	OFF	OFF
Test input	ON	OFF	ON	OFF	OFF
Break of light emitting element	ON	OFF	ON	OFF	OFF
Break of light emitting circuit	ON	OFF	ON	OFF	OFF
Stable light received	ON	OFF	ON	OFF	ON
Unstable light received	ON	OFF	ON	OFF	ON
Unstable light cut off	ON	OFF	ON	OFF	OFF
Stable light cut off	ON	OFF	ON	OFF	OFF
Break of light receiving circuit	ON	OFF	ON	OFF	OFF
Break of output element	ON	OFF	ON	OFF	OFF
Synchronous line malfunction	ON	OFF	ON	OFF	OFF
Over current	ON	OFF	ON	OFF	OFF
Ambient light received	ON	OFF	ON	OFF	OFF
Emitter failure	ON	OFF	ON	OFF	OFF

## Inspection / Treatment for malfunction

Malfunction	Caution	Treatment
Non-operation	Power Cut-off line, wiring failure	Supply rated power Check the wiring
Non-operation in sometimes	Pollution by dirt of sensor cover Connector connection failure	Remove dirt by soft brush or cloth Use within rated detecting distance Check the assembled part of the connector
Control output is OFF even though there is not a target object.	Out of rated detecting distance There is an obstacle to cut off the light emitted between emitter and receiver There is a strong electric wave or noise generator such as motor, electric generator, high voltage line etc.)	Use within rated detecting distance Remove the obstacle Put away the strong electric wave or noise generator.
Break of light emitting element LED displayed	Break of light emitting element	Contact our company
Break of light emitting circuit LED displayed	Break of light emitting circuit	Contact our company
Break of light receiving element LED displayed	Break of light receiving element	Contact our company
Break of output element LED displayed	Break of output element	Contact our company
Synchronous line malfunction LED displayed	Synchronous line connection failure or cut off Break of synchronous circuit of emitter or receiver	Check the wiring Contact our company
Over current LED displayed	Control output line shorted Over load	Check the wiring Check the rated load capacity
Ambient light receiving LED displayed	Ambient light received to receiver	Remove the ambient light
Emitter malfunction LED displayed	Emitter malfunction	Treat after checking the emitter display LED

## Caution for using

- Please, make the interval enough between 2 sets or exchange the positions of emitter and receiver in order to remove interference as occurring interference by the emitter of another set when using emitter/receiver more than 2sets closely.
- Please, install this sensor at proper height (Min. approx. 0.5m) from flat part as malfunction may be caused due to certain amount of light received by light reflected when installing it close to flat part.
- Please, avoid fluorescent light with high frequency, high speed start or signal light affecting to detection ability.
- Please, use a single conduit or separated wiring as it may cause malfunction or mechanical trouble when installing the wiring of the sensor with high voltage lines.
- Please, avoid these kinds of places with corrosive gas or dust as it may cause malfunction.
- Please make power and output line as short as possible as it may cause malfunction by surges etc. if the lines is long. (Max. 30m)
- Please, clean the sensor cover with dry cloth when it is stained by dirt etc., but don't use organic materials such as the kinds of thinners.
- Please, earth F.G terminal as following figure and install the condenser for removing noise between 0V and F.G terminal when using switching power supply.  
\* It may cause malfunction if above instructions are not followed.

## Main products

- COUNTER
- TIMER
- TEMPERATURE CONTROLLER
- PANEL METER
- TACHO/LINE SPEED/PULSE METER
- DISPLAY UNIT
- PROXIMITY SENSOR
- PHOTOELECTRIC SENSOR
- FIBER OPTIC SENSOR
- PRESSURE SENSOR
- ROTARY ENCODER
- SENSOR CONTROLLER
- POWER CONTROLLER
- STEPPING MOTOR & DRIVER & CONTROLLER
- LASER MARKING SYSTEM(CO<sub>2</sub>, Nd:YAG)

**Autonics Corporation**  
http://www.autonics.com

**Satisfiable Partner For Factory Automation**

**HEADQUARTERS:**  
41-5, Yongdang-ro, Ulsangang-eup, Yangsan-si, Gyeongsang, 626-847, Korea

**INTERNATIONAL SALES:**  
Bldg. 402 3rd Fl., Bucheon Techno Park, 193, Yangdae-dong, Wonmi-gu, Bucheon-si, Gyeonggi-do, 420-734, Korea  
TEL: 82-32-329-0722 / FAX: 82-32-329-0728  
E-mail: sales@autonics.net

EP-KE-77-0004C